

Please do not upload this copyright pdf document to any other website. Breach of copyright may result in a criminal conviction.

This document was generated by me Colin Hinson from a document held at Henlow Signals Museum. It is presented here (for free) and this version of the document is my copyright (along with the Signals Museum) in much the same way as a photograph would be. Be aware that breach of copyright can result in a criminal record.

The document should have been downloaded from my website <https://blunham.com/Radar>, if you downloaded it from elsewhere, please let me know (particularly if you were charged for it). You can contact me via my Genuki email page:

<https://www.genuki.org.uk/big/eng/YKS/various?recipient=colin>

You may not copy the file for onward transmission of the data nor attempt to make monetary gain by the use of these files. If you want someone else to have a copy of the file, please point them at the website (<https://blunham.com/Radar>).

Please do not point them at the file itself as the file may move or be updated.

I put a lot of time into producing these files which is why you are met with this page when you open the file.

In order to generate this file, I need to scan the pages, split the double pages and remove any edge marks such as punch holes, clean up the pages, set the relevant pages to be all the same size and alignment. I then run Omnipage (OCR) to generate the searchable text and then generate the pdf file.

Hopefully after all that, I end up with a presentable file. If you find missing pages, pages in the wrong order, anything else wrong with the file or simply want to make a comment, please drop me a line (see above).

It is my hope that you find the file of use to you personally – I know that I would have liked to have found some of these files years ago – they would have saved me a lot of time !

Colin Hinson

In the village of Blunham, Bedfordshire.

THE LOCKING REVIEW

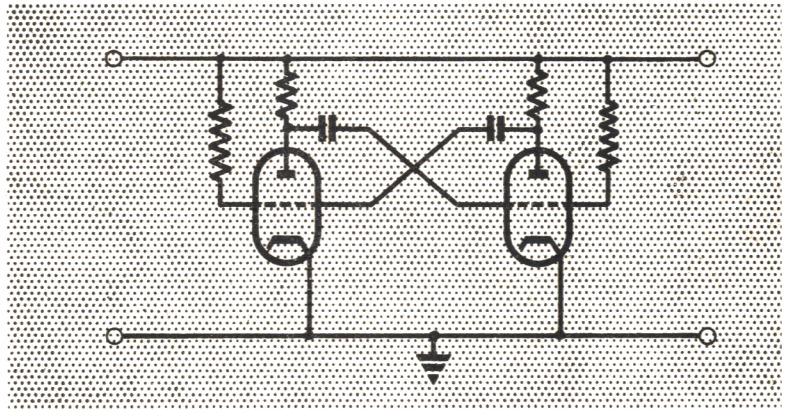

SUMMER 1964



SOLDERING INSTRUMENTS

HIGHEST STANDARDS
OBTAINED

*Catalogues
apply direct to
Head Office Sales and Service*

ADCOLA PRODUCTS LTD.

Adcola House - Gauden Road - London S.W.4

Telephones :
MACaulay 4272 & 3101

Telegrams :
SOLJOINT London S.W.4



Snap your fun

in COLOUR



with a new Kodak camera

J. & V. James

R.A.F. Newshop, Locking, Weston-super-Mare, Somerset

AT YOUR SERVICE

THOMAS HANSFORD

3-4 The Centre

Weston-super-Mare

Tel. 750/1

TAILOR AND OUTFITTER

For All

Service Uniforms and Accessories

R.A.F. ENTRY BADGES

Owing to heavy stocks we are offering the following Entry Badges at a special price.

	Silk	Wire
89th	15/-	30/-
91st	”	”
92nd	”	”
93rd	”	”
94th	”	”
95th	”	”
96th	”	”
98th	”	”
99th	—	63/-
102nd	—	63/-

NO. 1 RADIO SCHOOL SILK BADGES 12/6

G.C. STRIPES

MINIATURE MEDALS TO ORDER.

R.A.F. SHIRTS, DRESS SHIRTS &

WHITE DRESS WAISTCOATS

AGENTS FOR R.A.F. BATES SERVICE HATS

REVIEW

APPRENTICE WING
No. 1 RADIO SCHOOL
ROYAL AIR FORCE, LOCKING

VOL. 1, No. 7

Price 2/- (2/6 post free)

by kind permission of the Commandant:
AIR COMMODORE C. R. C. HOWLETT

Editor	A. G. Smith, M.A.
Assistant Editor	Flt. Lt. T. G. Nelson, M.A.
Business Manager	Flt. Lt. K. G. Evans
Sports Editor	Sgt. McKeever
Photographs	E. V. Wheeler
Line Drawings	D. Bate
Advertising Agents	Combined Service Publications Ltd.

Contributions, letters and orders should be addressed to:—
The Editor, Locking Review,
Royal Air Force, Locking,
Weston-super-Mare, Somerset.



Official photograph—Crown Copyright reserved

AIR TRAFFIC CONTROL RADAR

This photograph shows radar consoles with computer-fed displays for up-to-the-second information on impending aircraft movements—a development providing higher efficiency and safety in Air Traffic Control. This is typical of the advances which WIRELESS WORLD surveys month by month throughout the electronic, radio, television and audio fields. Latest techniques and components. Design of circuits. New equipment. Theory and practice. Charting the progress of electronic technology on every front, and in every country, WIRELESS WORLD is your most vital information source.

2s.6d. MONTHLY FROM ALL NEWSAGENTS
£2.0.0 a year by post. Special Student's rate £1.0.0

Wireless World

ELECTRONICS - RADIO - TELEVISION

ILIFFE ELECTRICAL PUBLICATIONS LTD., DORSET HOUSE, STAMFORD STREET, LONDON, S.E.1.

Contents

	PAGE
EDITORIAL	7
98th ENTRY:	
PASSING OUT PARADE	9
ADDRESS BY REVIEWING OFFICER	10
PRIZE LIST AND ACHIEVEMENTS	13
POSTING LIST	14
POEM	15
PROFILE: AIR COMMODORE C. R. C. HOWLETT	16
PHYSICAL FITNESS	18
FROM MENDIP TO THE SEA: CHAPTER IV	19
THE KEEPING OF TROPICAL FISH	25
ROVING REPORTER IN A "Z" CAR	29
BEETHOVEN, BERLIN AND BEATLES	33
THE ROLE OF THE COMPUTER IN BANKING	35
THE HISTORY OF FENCING: PART I	39
SPORTS AND SOCIETIES:	
BOXING CLUB	37
ART CLUB	41
STATION RUGBY FOOTBALL CLUB	43
CANOE CLUB	44
FENCING CLUB	46
GLIDING CLUB	47
AIRCRAFT RECOGNITION CLUB	49
GOLF SOCIETY	49
TABLE TENNIS CLUB	51
SADDLE CLUB	51
EX-APPRENTICE CORNER	51

See the . .

AUSTIN MINI

M
O
T
O
R
I
N
G
S
C
H
O
O
L
O
F

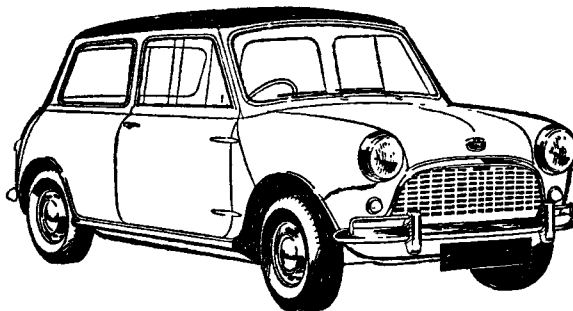

Y
E
L
L
S
R
I
A
C
R
R

SALES AND SERVICE — AT

PASSEY & PORTER LTD.

Locking Road, Weston-super-Mare
and Winscombe, Somerset

Telephones : Weston-super-Mare 4445/6 - Winscombe 2224/5

CULLEN'S (Langford) Ltd.

Langford, Nr. Bristol

'Phone Wrington 203

FORD



HILLMAN

Hillman Imp

*JENSEN Distributors for Somerset,
Wiltshire and Gloucestershire*

Editorial

There are two or three items in this issue worthy of comment, agreeable or otherwise.

We are delighted to note that two of our features have come to us from ex-apprentices, who have not completely severed their ties with Locking and we should like to see more of this sort of contribution. After all, it is fitting that the *Review* should form a link between No. 1 Radio School and its ex-members and also, perhaps, between the ex-members themselves.

On the other hand, however, readers will find, elsewhere, around “Ex-Apprentice Corner”, a plea from our Business Manager, in which he stresses the difficulties facing the *Review* staff at the moment, and asks for the advice and co-operation of our readers. His views are those of all the staff, of course, but he, no doubt, feels our problems more acutely, as he has to sell the magazine and try to balance the books.

The fact is, that we want more people to buy *The Locking Review* and we want to make it a more attractive buy—better value for the money, if you like. The two factors are closely linked: unless most apprentices and many ex-apprentices, not to mention permanent staff and airmen, buy copies, we shall never have sufficient funds to improve the quality of the journal, while, conversely, if we cannot improve the quality or increase the size, it will become increasingly difficult to sell.

It really is up to you—our readers—therefore. Buy it, tell us what you think of it, preferably politely, and better still, send us your own contributions and suggestions for improvement. Remember, it is your magazine—we only work here!

Once more we must say farewell to a member of the magazine staff and thank him for his efforts. Flight Lieutenant Barnes has left the Service and we wish him every success in civilian life. We should like to welcome his successor, Flight Lieutenant Evans who has, in fact already attacked our problems with considerable energy.

A final sad duty is to record and announce to more distant readers, who may not have heard the news, the death of Hamish McCrackers, on 21st May, 1964, after nearly eleven years of faithful service. He will be greatly missed by all, and we are glad that we were able to pay light-hearted tribute to him in our last issue. His place has not been vacant for long and we hope that his successor, 295 Apprentice Air Pony Heathers McCrackers, will enjoy a long and distinguished service career. We look forward to featuring him at greater length in our next issue, after his ceremonial début on the occasion of 99th Entry Passing Out Parade.

FORTE'S

*Soda Fountain and
Ice Cream Parlour*

Everything of the Finest

Open all the year round

**Ice Cream & Soda Fountain
Products**

Milk Shakes, Coffee, etc.

**4 & 5 Beach Road
50a Knightstone Road
14 The Centre
Weston-super-Mare**

Telephone
No. 1789



Passing Out Parade of the 98th Entry of Aircraft Apprentices

Reviewing Officer : Air Marshal Sir Christopher Hartley,
K.C.B., C.B.E., D.F.C., A.F.C., B.A., Deputy Chief of the Air Staff

Parade Commander

Entry Commander

Parade Warrant Officer

F.S.A.A. Bengree, N. J.

S.A.A. Dorey, V. S.

S.A.A. Palmer, N. R.

Supporting Squadron

Supporting Squadron Commander

S.A.A. Saunders, M.G.

No. 1 Radio School Apprentice Pipe Band

Warrant Officer T. D. Williams, L.R.A.M., A.R.C.M.

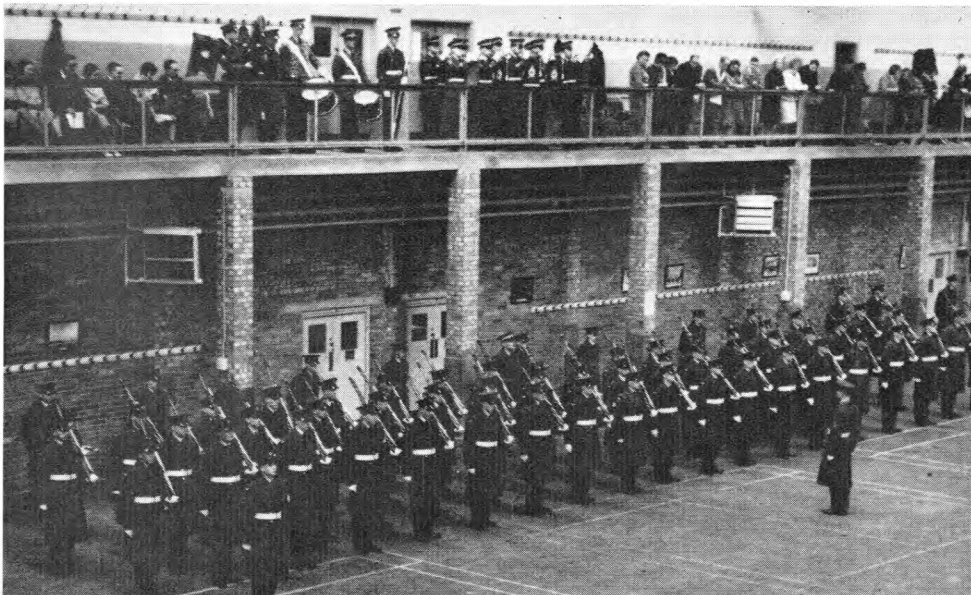

Address made by Air Marshal, Sir Christopher Hartley, K.C.B., C.B.E., D.F.C., A.F.C., B.A., Deputy Chief of the Air Staff, on the occasion of his Review of the 98th Entry of Aircraft Apprentices at their Passing Out at Royal Air Force Locking, on Tuesday 24th March, 1964.

The Air Marshal said:

Commander-in-Chief, Chairman of the Axbridge Rural District Council, Your Worship the Mayor of Weston-super-Mare, Ladies and Gentlemen:

I have always considered it rather a barbarous habit at the close of a ceremony like this, that the Reviewing Officer is let loose to inflict his views on people who have no form of redress, and I have also been told that it is customary for the Reviewing Officer to give a speech of 1½ hours or so, but I propose to cut my speech—to not more than 55 minutes anyway!

I would first of all like to say how grateful I am to the Commander-in-Chief for having given me the opportunity to escape from my desk, even for a brief period. As you have heard, my job is concerned with the future of the Royal Air Force, and it is very important from time to time to remind oneself that it also has a “present”, particularly when one has the opportunity of visiting an important technical training establishment such as this. This, however, is not the only debt I owe to your Commander-in-Chief. During the war I took over a unit, as a very raw inexperienced reservist, which he had previously commanded, and I am quite certain that if he had not laid such sound foundations, I would have got myself into very serious trouble and, very certainly, would not be here today.

I am very pleased, also, to add my greetings to those of the Commandant, both to the Chairman of the Axbridge Rural District Council and the Mayor of Weston-super-Mare, who are here today. A previous posting of mine was as an A.O.C. of a Fighter Group and I learnt once again how valuable and important close relationships—

and good relationships—are, between the service and civil life. We do not have so many stations these days, but one must remember that, where we have got a station, it forms a fairly large chunk of humanity and whilst, inevitably, much of our activity is centred inwards into life on the Station itself, it is truly wrong just to confine ourselves to that—we are citizens as well as airmen. I think that good relationships which have been built up, are of tremendous value to us and I like to think, and I hope, that they are of value in the community in which we are living. It was not always like this. Going back to the 18th century, the armed forces, in the shape of the soldiery—there were no airmen in those days and the sailors were not allowed ashore—were regarded as the lowest form of animal life. Thank goodness that has changed, and it is up to us to play as full a part in the life of the community we live in as we can.

I would also like to add my greetings to the parents, both of the passing out entry and the junior entry. I was once a schoolmaster myself for two years—a man called Hitler put a stop to it—but I was a schoolmaster long enough to appreciate the importance of the parent/teacher relationship, and I think that what you have seen today will help to create a confidence between you and the staff here.

Locking is a forward looking institution and it has to be. We are training here for the trades of the future and the training is the best we can devise. But, of course, in the field of electronics, new techniques are constantly being developed and the staff here has to keep the training under review and up-to-date, so that they are able, as soon as they see new developments emerging, to adapt them to the training here, and I believe they are doing this job to the very best of their ability.

Finally, I would like to say just a few words to the Passing Out Entry.

First of all, I think it was very bad luck on you that it rained today because I know how much harder it is to put on a parade indoors, with a very slippery floor. Also it has the disadvantage of putting you rather closer to the Reviewing Officer than you would otherwise be. I would like to congratulate Flight Sergeant Aircraft Apprentice Bengree, and all of you, on the smartness of your parade and the way in which you surmounted these difficulties. It was well up to standard.

I do not need to spend a lot of time stressing the importance of your field of technology within the Royal Air Force. It pervades the whole service, in manned aircraft and missiles, and in the way in which we control and operate our weapons and direct our forces, so as a service we are especially dependent on you and men like you, in the future.

A word about the future—but not very much. The future is fascinating. It is only too easy to get fascinated by it to the exclusion of the present, but for most of us, and for most of our service careers, the present is the important thing. We have equipment in the service and we have to make it work—we have to make it work now, not on Friday week or next year. Modern weapons are tremendously expensive and therefore we cannot, with the best will

in the world, afford large numbers of weapons and aircraft in our front line. We are relatively well off as a country but we cannot afford the enormous air forces which we could afford up to about ten years ago, so it becomes all the more important that we should get the maximum use out of all the equipment we have been able to buy, and that is where you come in.

If I had to pick on one thing out of my experience, on how to get the best out of the front line, I would say this. I think it comes from the combined efforts of everyone paying the utmost attention to detail. This sounds dreary, I know, but it is really important—there is no short cut to efficiency. Efficiency can be summed up as collective hard work and attention to detail by everyone involved and if these principles are applied, in some mysterious way—you cannot put your finger on any one thing—you will find that the efficiency of a front line force like a Group, will rise steadily and perceptively.

Over the two years that I had the good fortune to command my Group, we started off with fairly new aircraft, with not enough flying hours to keep the pilots really in practice, but, after two years, we had so many serviceable aircraft that the pilots could not possibly fly all the hours available. This is the state of affairs that we are aiming for with every new weapon we introduce. Of course, this does not come overnight, nor from one master mind organising it, it only comes from the collective efforts of all of you and others like you. So, as my brief advice to you, to get the full enjoyment and a full life out of your time in the Service, I would say just this—remember that the success of the job as a whole depends on everybody working in detail to the very highest standards. Always set yourselves—and demand from yourselves—the very highest standards in all your work. Never fall into the temptation of skimping the job and never be content with a second-rate performance on your own part. You may get away with it, but it is not possible for you or anyone else to predict what is going to happen if the very highest standards are not achieved. It may mean that an aircraft is not serviceable and people are killed—it may merely mean that the aircraft is not ready as soon as the Squadron Commander wanted it.

I think that this is enough good advice. I am quite certain that your training here has done all that it can have done for you.

I wish you all the very best of luck in the future. I think that the levels to which each or any of you can rise will be finally determined by your own efforts. There isn't any ceiling—remember that.

Thank you.



Cortina De Luxe

Make the most of your privileges **DRIVE A TAX-FREE BRITISH FORD**

British Fords are top cars—everywhere. Fast Flat Autobahns or dirt tracks, British Fords can take it in their stride—with COMFORT, economy and reliability.

You can have priority of any car in the superb Ford range if you are posted abroad . . .

YET YOU PAY NO BRITISH TAX!

You can use your new Ford in Britain for up to six months prior to leaving, or you may qualify

for up to twelve months between overseas postings. Alternatively, Ford will arrange shipment direct to you. Hire purchase facilities are available. Remember, wherever you are posted you'll find world-wide Ford service.

THE FORD RANGE INCLUDES:

A complete range of Saloons, Estate Cars and G.T. high performance cars. For full details of any model(s) fill in the coupon below:

INT.F.87

Please send me without obligation, full details of the British Ford model I have ticked below and your personal export scheme.

NAME..... B.F.M.

FULL ADDRESS.....

I AM BEING POSTED TO.....

ANGLIA CORTINA CORSAIR ZEPHYR 4 ZEPHYR 6 ZODIAC

Cut out this coupon and post to: FORD MOTOR COMPANY LIMITED, 88 REGENT STREET, LONDON W1 • Telephone: REGent 7272



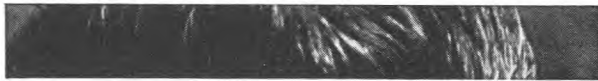

I LIKE THEM

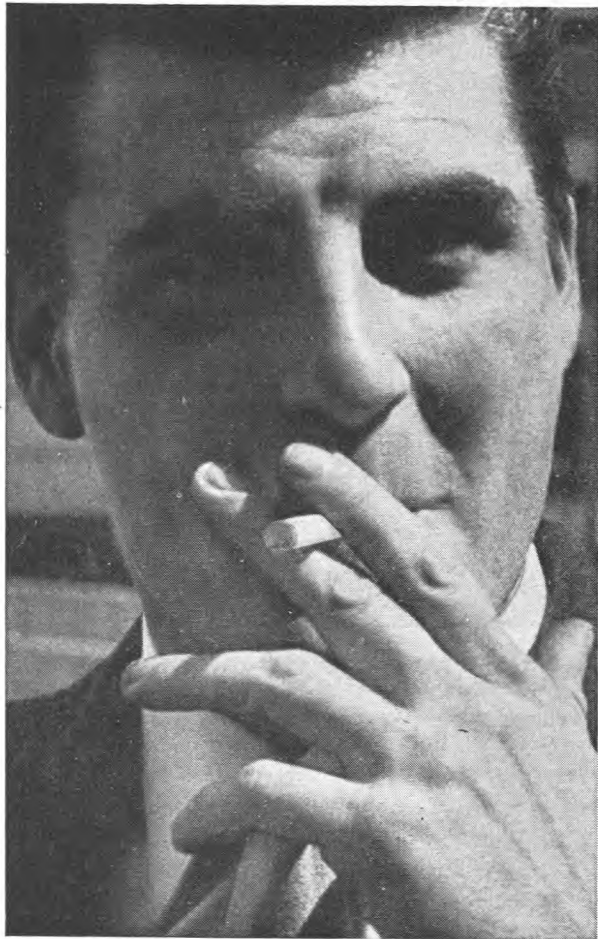

**PARK
DRIVE**

Really good value at 3/8 · Tipped-3/1



**FOR
STRIKING
RESULTS**



BRITISH MADE BY BRYANT & MAY



BY APPOINTMENT
TO HER MAJESTY THE QUEEN
BISCUIT MANUFACTURERS

*fastest selling-
freshest tasting!*



**LOOK FOR THE PACK
THAT'S ORANGE & BLACK**

Prize List and Achievements

Lord Trenchard Memorial Prize	F.S.A.A. Bengree, N. J.
British Institution of Radio Engineers Prize	A.A. Tripp, D. S.
Royal Aeronautical Society Prize	S.A.A. Price, N. F.
Air Ministry Prize for First in Order of Merit	S.A.A. Price, N. F.
Air Ministry Prize for Best Air Radio Fitter	A.A. Clarke, B. B.
Air Ministry Prize for Best Ground Radar Fitter	A.A. Fergusson, A. C.
Air Ministry Prize for Best Ground Wireless Fitter	S.A.A. Price, N. F.
Air Ministry Prize for Educational Subjects	A.A. Tripp, D. S.
Air Ministry Prize for General Service Efficiency	F.S.A.A. Bengree, N. J.
Air Ministry Prize for Best Manual Exercise	A.A. De Ryck, W. R.
Air Ministry Prize for English and General Studies	S.A.A. Price, N. F.
Air Ministry Prize for Best Set Task	A.A. Roberts, T. J.

WING TROPHIES

Victor Ludorum Trophy S.A.A. Rafferty, M. R. **Wing Championship** "A" Squadron

WING COLOURS

The following Apprentices of the 98th Entry have been awarded Wing Colours in the sports shown:

Soccer	F.S.A.A. Bengree, N. J. A.A. Gray, B. J.	Rugby	S.A.A. Rafferty, M. R. S.A.A. Jenkins, J.
Water Polo	C.A.A. Larner, P.A. C.A.A. Watson, S. B.	Swimming	C.A.A. Larner, P. A. A.A. Jukes, G. V.
.22 Shooting	S.A.A. Dorey, V. S.	.303 Shooting	A. A. Bastable, B. A.
Canoeing	A. A. Harvey, J. D.	Boxing	C.A.A. Watson, S. B.
Cricket	A.A. Barnes, R.	Hockey	S.A.A. Price, N. F.

98th Entry Posting List

686774	J/T Bastable, B. A.	R.A.F. Marham
687318	J/T Clarke, B. B.	R.A.F. Coningsby
687341	J/T Fenwick, D.	230 O.C.U. Finningley
687328	J/T Harris, I.	R.A.F. Marham
687346	J/T Oxley, D. W.	44 Sqn. Waddington
687348	J/T Penny, K. D.	R.A.F. Scampton
687314	J/T Boyd, P. M.	3 F.T.S. Leeming
687325	J/T Foster, K.	R.A.F. Finningley
687330	J/T James, J. A.	R.A.F. Marham
687335	J/T Knott, H. G.	R.A.F. Marham
687334	J/T Lerner, P. A.	232 O.C.U. Gaydon
687342	J/T May, S. J.	R.A.F. Waddington
687343	J/T Merriman, S. J.	1 F.T.S. Linton-on-Ouse
687369	J/T Roberts, T. J.	R.A.F. Coningsby
687364	J/T Turpin, J. L.	R.A.F. Cottesmore
687365	J/T Underhill, B. K.	5 F.T.S. Oakington
687197	J/T Watson, S. B.	6 F.T.S. Acklington
687368	J/T Webber, G. F.	R.A.F. Waddington
687308	J/T Bailey, C. B.	R.A.F. Patrington
687311	J/T Benford, J. F.	R.A.F. Buchan
687323	J/T Druett, J.	R.A.F. Boulmer
687324	J/T Fergusson, A. C.	R.A.F. Patrington
687326	J/T Gray, B. J.	R.A.F. Boulmer
687336	J/T Levesley, M.	R.A.F. Boulmer
687355	J/T Robinshaw, P. V.	R.A.F. Boulmer
687357	J/T Rutter, C. N.	R.A.F. Boulmer
687338	J/T Surtees, J. W.	R.A.F. Buchan
687312	J/T Arnot, F. S.	R.A.F. Bawdsey
687309	J/T Barnes, R. K. B.	R.A.F. Patrington
687317	J/T Campbell, J.	R.A.F. Buchan
687320	J/T Croft, D. M.	R.A.F. Buchan
687329	J/T Harvey, J. D.	R.A.F. Buchan
687362	J/T Thorley, L. D.	R.A.F. Buchan
687310	J/T Barton, M.	R.E.U. Henlow
687331	J/T Jarvis, R. H.	R.E.U. Henlow
687332	J/T Jenkins, J.	R.E.U. Henlow
687352	J/T Reilly, L. A.	R.E.U. Henlow
687354	J/T Roberts, G. J.	R.E.U. Henlow
687356	J/T Russell, A. M.	R.E.U. Henlow
687337	J/T Saul, D. F.	R.E.U. Henlow
687363	J/T Tripp, D. S.	R.E.U. Henlow
687367	J/T Wilks, B. P.	R.E.U. Henlow
687319	J/T Cornforth, J.	R.A.F. Wyton
687321	J/T De Ryck, W.	R.A.F. Ballykelly
687333	J/T Jukes, G. V.	R.A.F. Cottesmore
687347	J/T Palmer, N. R.	C.F.S. Little Rissington

687350	J/T Rafferty, M. R.	R.A.F. Cottesmore
687351	J/T Reed, N. G.	R.A.F. Scampton
687359	J/T Stares, D. M.	242 O.C.U. Thorney Island
687316	J/T Buttery, D.	R.A.F. Boulmer
687360	J/T Sutton, T.	R.A.F. Patrington
687196	J/T Parker, D. H.	R.A.F. Patrington
687327	S.A.C. Good, S. A.	R.A.F. Bawdsey

Direct Entry Commissions

687349	Cpl. Price, N. F.	O.C.T.U. Feltwell
687339	J/T Thirlwall, C.	No. 1 I.T.S. South Cerney

Substantive Corporals

687322	Cpl. Dorey, V. S.	R.E.U. Henlow
687313	Cpl. Bengree, N. J.	R.A.F. Scampton

' . . . I DIDN'T THINK '

by J/T B. P. WILKS

(Ex 98th Entry)

There is a short excuse I know
 It reads so very easily though—
 Too easy—to provide the missing link:
 ' . . . I didn't think! '
 And yet this simple thing,
 So easily said, can surely bring
 More sorrow, pain, worry, strain
 Than any other can contain.

Man, with spirit of decision,
 Is led to trouble and oblivion;
 Into the depths of a phrase he'll sink:
 ' . . . I didn't think! '
 Grovelling at this dastardly plane
 Conscience sings no sweet refrain:
 'Senseless fool, troubled till you'll
 Allow common sense, and thought to rule.'

I say I'm sorry; That's very kind!
 I caused the suffering, I acted blind.
 I closed my eyes, I didn't blink:
 ' . . . I didn't think! '
 Who'll forgive the faults of man?
 Only Gods, for there is no man
 In this whole land
 Who can—or will—understand.



Profile:

AIR COMMODORE C. R. C. HOWLETT

Air Commodore C. R. C. Howlett was educated at Bedford School and joined the Royal Air Force, on a Short Service Commission in the General Duties Branch, in 1936. After undergoing training as a pilot at No. 3 Flying Training School, Grantham, he was posted to No. 9 Squadron for flying duties.

In January 1941, after completing the Specialist Armament Officers' Course at R.A.F. Manby, he was posted, first to the staff of Air Headquarters, Greece, and then, with the fall of Greece, to R.A.F. Heraclion on the Island of Crete. With the capitulation of the Island, Air Commodore Howlett was taken prisoner by the Germans and, after being in many prisoner of war camps, eventually ended up in Stalag Luft III, near Posen. When the advance of the Russians, in January 1945, threatened to over-run the camp, he was moved further to the west, to a camp near Bremen. Eventually he was released by the British Army and returned to this country on V.E. Day, 1945.

After an Armament Refresher Course at the Empire Air Armament School, then at R.A.F. Manby, he joined the Staff of the School, first as a Course Officer and then, on promotion to Squadron Leader, as Officer i/c Armament Officer Training. Air Commodore Howlett was granted a Permanent Commission in the Technical Branch in 1947.

Upon completing the interim Combined Technical Course, he was posted in 1948 to the Air Ministry, to the Directorate of Technical Training, and then, after taking the Senior Specialist Armament Officers' Course, at the Empire Air Armament School, he was posted in 1950 to the Ministry of Supply, as it was then, to the Directorate of Research and Development (Aircraft).

His specific responsibility was the installation of Armament Equipment in aircraft being designed and developed for the Services.

In 1951, he was promoted to Wing Commander and posted to the Air Ministry to the Directorate of Operational Requirements. This tour of duty was then followed by a three year tour with the United States Air Force as an Exchange Officer in the Weapons Guides Laboratory, Wright Air Development Center, Wright Patterson Air Force Base, Dayton, Ohio.

Upon returning to this country in 1958, he was posted first to the Staff of Headquarters Fighter Command as the Command Armament Officer, for a short while, and then promoted to Group Captain and posted to the Air Ministry as the Deputy Director of Armament Engineering. In 1959, this Deputy Directorate was amalgamated with the then Directorate of Guided Weapons and, under the revised organisation, Air Commodore Howlett filled the post of Deputy Director of Weapons Engineering (3). This posting was followed by three years as the Superintendent of Armament at the Ministry of Aviation's Aircraft and Armament Experimental Establishment at Boscombe Down.

Air Commodore Howlett is married and has three children; two daughters who are at a boarding school in Buckinghamshire and a ten-months-old son.

Comments on Physical Fitness

by THE SPORTS EDITOR

Fit for what?

This is a question we sometimes hear, usually in reply to the statement made about someone, that "he is very fit".

Fit for what indeed? The answer is often given in the same vein as the answer to that other famous question, "What shall I do with it?".

The fitness tag is usually attached to those who have bulging biceps, whereas, in fact, there are many different types of fitness: for example Herb Elliott the World Record miler looked more like a fugitive from Belsen, but who would question his stamina? He didn't have the bulging muscles but he did have a strong heart and strong lungs.

There is also the fitness to endure hardship over a long period of time; this ability to endure often comes from a state of mind, a sheer determination not to give in as was shown by some of our war-time aircrew, who when shot down over the sea, had to survive for days, sometimes without food and water. The average man, with this determination, can "hold out" longer than a trained athlete, who has little motivation. But obviously, physical fitness allied to this mental outlook is of greatest benefit.

Everyone in the Royal Air Force is fit, at least to a required standard, otherwise we would be medically discharged. However, it is recognised that the serviceman should be of a higher standard of fitness than his civilian counterpart, simply because of this service life. We don't have to be supermen, but how far have you walked today? The answer to this question might well be, for a lot of us, "To and from the car".

A very good exercise, to those of us who are slightly on the corpulent side, is, when sitting at a table, to stretch the arms vigorously forward and push that plate away.

Our old friends the Ancient Greeks were very keen on physical fitness, especially in their young men, who trained, usually naked, in the Palaestra, which was part of a larger building or school called the Gymnasium.

The Romans, unlike the Greeks, did not favour games too much, but preferred expedition training, camping and route marches. So the next time Apprentices are limping over Exmoor completing their D. of E.'s it might help them to know that they weren't the only ones. Kilroyus was here!

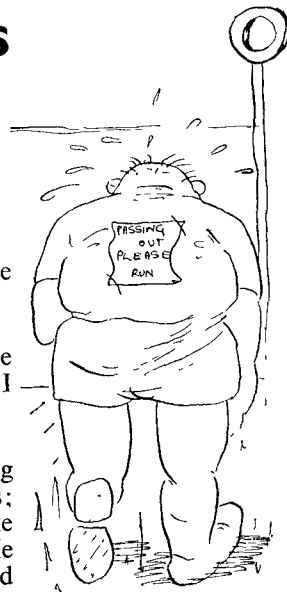

Pick the creamy
Salad Cream
that goes
straight to
the heart
of a
lettuce
Pick the
best-
pick

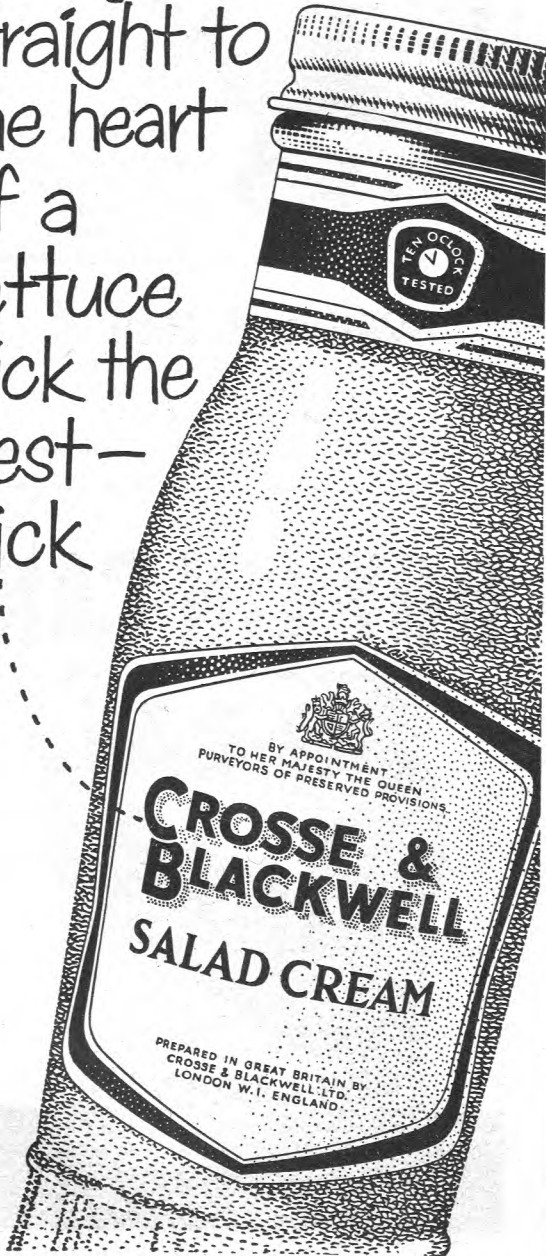

Don't be
vague
Ask for
Haig



BRITAIN'S LARGEST-SELLING
SCOTCH WHISKY



Mr. Peek and Mr. Freen have been on overseas service since 1857. You'll find them in service canteens and Naafis throughout the world.

Peek Freen

Makers of Famous Biscuits and Christmas Puddings

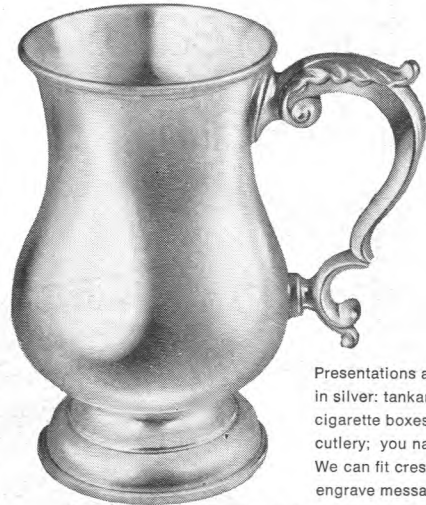

Presentations are better in silver: tankards, cigarette boxes, trays, cutlery; you name it. We can fit crests, engrave messages.

Our replating service can refresh the regimental silver, too

Write to

Walker & Hall



Howard Street, Sheffield

Silversmiths & cutlers since 1845

Avon House, 356/366 Oxford Street

(opp Bond Street Stn) London W1, Tel Mayfair 9818



Variety...
Quality...
Value

Jolly Lollies
Aniseed Balls
Nougat
Bubble Gum
Sherbet Fountains
Gob Stoppers
Chocolate Nougat
Licorice
Jamboree Bags
Coconut Ice

What a range for children

Barratts

BARRATT & CO. LTD., MAYES ROAD, WOOD GREEN, LONDON, N.22

BUY LIN-CAN

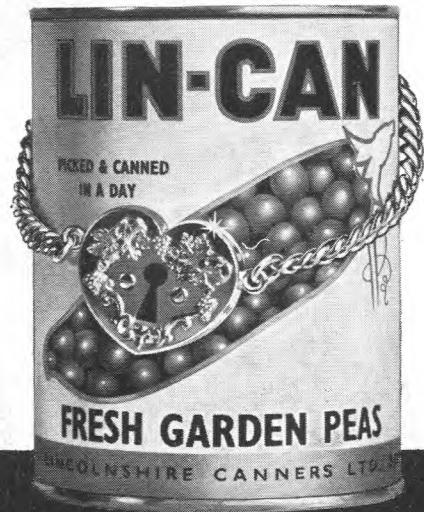

LINCOLNSHIRE CANNERS LTD BOSTON LINCOLNSHIRE

From Mendip to the Sea

A LOCAL HISTORY IN CHAPTER FORM

by OFFICER CADET P. HUTCHINS

R.A.F. Technical College, Henlow

Chapter IV: WESTON-SUPER-MARE

The Borough of Weston-super-Mare is a place of no history. Less than sixty years ago there were old men living who well remembered the days of small things; no post office, no delivery of letters, when not only beer, but bread, had to be brought from Worle, when the laying of the foundation stone of its first hotel was of such magnitude in the eyes of the villagers that a company of the West Mendip militia "Fired volleys from their flintlock muskets to celebrate the occasion".

It was, in the time of the Domesday Book, included in the Manor of Ashcombe, which was held by Arthur of Clapton in the reign of Henry III. The property passed by marriage to the Winters at the beginning of the sixteenth century and was bought by John Pigott in 1696. In the early part of the nineteenth century it was a small, far from prosperous, fishing village. A mere hundred or so villagers eked out a scanty living by shrimping and fishing. Always the catches had to be taken to Bristol, Bridgwater or Taunton and, by the time the carriers and market folk had taken their share, the fishermen got little enough for their netted harvest. The villagers offset the hazards of fishing by cultivating their own potato and cabbage patches. They also bred pigs in lean-to sties set against their cottage walls, or kept a cow or two on Weston Moor. The harbour was littered with rotten nets and buoys and the hill above was treeless, barren and buffeted by every blast of the Atlantic winds.

The birth of Weston as a resort may be reckoned to have been in 1808, when the fishermen's huts and other plots of land were sold by the Pigott family to Parsley and Cox. These two gentlemen obtained an Act of Parliament in 1810, under which the waste lands, over which the village Common Rights extended, were enclosed. Once having established itself upon the map, the reason for Weston's great fame and astonishing expansion is pinpointed most accurately by quoting a letter of Mrs. Piozzi, better known as Mrs. Thrale, the lady to whom Dr. Johnson wrote his "Letters from the Hebrides".

She says of Weston, in 1819, "The breezes here are most salubrious, no land nearer than North America when we look down the channel, and 'tis said that Sebastian Cabot used to stand where I sit now and meditate his future discoveries of Newfoundland. Who would be living at Bath now? The bottom of the town a stew pot, the top a Gridiron and London in a State of Defence or Preparation for Attack, or some Strong Situation, while poor little Weston is free from alarms on Juvenal's Principle, 'Cantabit vacuus coram Latrone Viator'".

Again, to quote from the "First Guide of Weston", 1822: "It is consequently open to the south-west winds, which generally prevail during the summer months, and which are uncontaminated by passing over any land which can rob them of their peculiar salubrity". Sir Humphry Davy attributed this "salubrity" to the large portions of oxygen the south west winds imbibe in passing over the vast vegetations of the extensive plains of the Savannahs of South America! Indeed, in the 1820's, the soft balmy airs of Weston received much favourable comment in the upper circles (no doubt as the Prince Regent himself had dipped himself in the brine at Brighton in 1810); Weston's career and growth as a health centre and sea-side resort had commenced.

For its rapid rise to favour, Weston is largely indebted to Dr. Fox, an eminent physician of Brislington who, seeing how well the place was suited for a health resort, had much to do with the early improvement of the town. He purchased Knightstone Island in 1830 and spent between £16,000 and £20,000 providing accommodation and salt water baths for his wealthy patients. He also improved the Knightstone harbourage and made the causeway which links the island to the mainland.

The next important trend of development is the introduction of the railway. This occurred in 1841. The old Bristol and Exeter Railway Company originally intended that the line should run direct to Weston. However, the townsfolk bitterly opposed the presence of those "evil smelling things" and thus the directors diverted the line to the open moor, some miles or so distant from Weston. This necessitated the use of a horse drawn spur, which operated between the junction and the station, which was then situated where the floral clock is now to be seen. The train consisted of three four-wheeled coaches, as light and as small as broad gauge vehicles could well be made, drawn by three horses in tandem fashion. Each horse was ridden by a lad, but the quality of steeds was not high. The absence of shafts and of a quick acting break power made the work extremely dangerous for both horses and riders and there is record of many accidents. Indeed this is one occasion where the people of Weston were guilty of a short-sighted policy. In 1866 a much improved station came into use just behind the present day Odeon Cinema and then in 1884 the new loop line was inaugurated, with a station in its present day position. The Westonians had realised their folly. "We may spend thousands of pounds in extending and beautifying our sea front, in building piers, laying out gardens and providing other alterations, but unless facilities are given for bringing visitors to the town, we spend our money and labour in vain". The new passenger station was built by Mr. J. Hartley, of Birmingham. "Its appearance inside and out is decidedly pleasing and effective. It is a long low building, Gothic in style, and

the skyline is considerably broken, a very good effect being produced by the height of the towers over the staircases”.

In 1867 Birnbeck Pier, better known today as the Old Pier, was constructed, after much opposition from the local gentry of half-pay colonels, superannuated bank officials and retired Bristol Merchants, who were very irate to gain the knowledge that the peace of their precious “Cliftonville” might be shattered by the noise of commerce. The pier projected some distance beyond the little rocky islet of Birnbeck, on which the pavilion was built, as a construction of timber and iron piles about 250 feet in length, to be used as a landing stage. There was a large fire in December of 1897 which destroyed all the principal buildings, but apparently good came from the evil, as the directors of the Pier Company used this as a reason to make the buildings thoroughly up-to-date for their time. Birnbeck juts straight out into the Channel from Worlebury Hill and today houses the life-boat station. It is a place of the breezes for which Weston is favoured, which brace impaired nerves, quicken the flagging appetite and invigorate the “dilapidated frame to a pitch of joyous energy”. Away down the channel can be seen Watchet, Minehead, Porlock, Dunkery Beacon (the loftiest point in Somerset) and across on the Welsh coast the Naas Sands and lighthouse, Barry Docks, Penarth, Cardiff, the Welsh mountains in the background, with Breconshire Beacon, the Malvern Hills and the Monmouthshire Beacon. To the north may be observed Clevedon, Woodspring Priory, Sand Bay and so round the curving coastline to Weston.

During the war a resourceful Royal Naval Lieutenant by the name of Francis was despatched on a tour of the West Country to locate a site for use as a development centre of the Royal Navy's D.M.W.D. (Department of Miscellaneous Weapon Development). Somewhere was needed with a high rise and fall of tide over sand or mud; experimental projects had to be fired into deep water and then recovered undamaged when the tide receded. It was not long before Francis's observant eye rested on Birnbeck. Noting the plenty of buildings, easily adaptable as workshops, and the distinct advantages from the security angle, the Admiralty soon descended and the pier became known as H.M.S. *Birnbeck*. For the rest of the war it was destined to play a memorable part in the Navy's scientific research.



UPHILL CHURCH AND BREAN DOWN

The appearance of “Wheezer’s and Dodger’s” at first caused considerable stir, as when they expanded from H.M.S. *Birnbeck* to Brean Down and Middle Hope Cove, many strange flying objects and muffled explosions were to be seen and heard. Soon, however, the stream of bombs, mines and other lethal looking objects aroused no more than a passing interest, although fellow passengers from Paddington to Weston never seemed quite at ease when sharing a compartment with a large bomb!

After Birnbeck the development was very brisk. In 1880, the townspeople resolved upon a £32,755 scheme to erect a barrier against the Atlantic breakers and, at the same time, provide an impressive Marine Parade. This was to have a spacious two-mile promenade, ample carriage ways and a Madeira Cove with pleasant rockeries and alcoves to serve as welcome sun traps. The sea front scheme took nearly seven years to complete, but long before it was finished the enterprising townsfolk were laying out Clarence Park and Prince Consort Gardens and effecting other improvements. In 1895 the Town Commissioners were replaced by an Urban District Council and the early activities of that body included the enlargement of the Town Hall, opening of Ashcombe Park, provision of a Public Library and Museum and purchase of Knightstone Island. Here, in 1902, they built a theatre, public swimming baths and medicinal baths. During these years, the course of private enterprise kept pace with municipal enterprise. The Royal West of England Sanatorium was opened in 1868, the trans-Atlantic submarine cable was laid in 1885, the Grand Atlantic was opened in 1889, telephones arrived in 1890 and electric lights in 1897. The town was served with electric trams in 1902 and the Grand Pier was opened in 1904. In those days the services rendered by Birnbeck Pier and the Grand Pier are the reverse of today. The Grand had a Pavilion standing a quarter of a mile from the shore which held 2,500 people. Productions included opera, musical comedy, the music hall, Shakespeare ballet and boxing. By 1906, the pier had been extended another mile out to sea, with the object of enabling a regular passenger service to Cardiff at all states of the tide. However, the tide and strong currents made the mooring of ships too dangerous and the scheme had to be abandoned. The extension was dismantled and re-erected as the long pier at Southend-on-Sea. In 1930 the pavilion was completely destroyed by fire. It was then rebuilt in its present form, without the theatre, and possibly without the performing flea circus which caused international controversy in 1952!

After the pier, more and more houses and hotels sprang up. In 1911 came the town’s first cinema, the Electric Theatre, which stood on the present site of the Odeon. The first floral clock appeared on Alexandra Parade in 1935 and the following year the Airport was opened and the council bought Weston Woods.

In 1937 Weston was raised to the status of a Borough, its Charter of Incorporation being the first to be granted in King George VI’s reign. The Pool is Weston’s greatest publicity making attraction. There are ten metres of diving stage, a stately structure

almost unequalled in the world. It holds 850,000 gallons of purified water and 1,500 bathers can sport at any one time. Indeed the scenes at the pool on a summer's day, not least when one of Weston's beauty parades is in progress, would certainly open the eyes of the sleepy old Weston fisherfolk of a mere hundred years ago!

True to their motto, on the Borough Arms, of "Ever Forward" the people of Weston also harbour thoughts on the future. This continuous and continuing expansion is the result of three factors—the appeal of Weston as a holiday resort, the number of people who choose to live in Weston on their retirement and the Council's policy of encouraging light industry by the allocation of sites and housing. The most dynamic of the futuristic redevelopment schemes is the Oxford Street–Carlton Street plan. The site is immediately behind the Town Hall and is bounded on four sides by Beach Road, Oxford Street, Walliscote Road and Carlton Street. The complete area is 7.002 acres and demolition work has already commenced. Much thought has been given to the project and it is to be approached with a resulting architecturally ambitious and memorable construction in mind. In the era of stifling and crowded roads the concentration of buildings into a number of relatively large units will provide open spaces offering pleasant relief from congestion. Use of high buildings will also be made to act as a recognisable focus to the centre of the town. Access for cars and delivery vehicles to all buildings, with the exception of the two on Walliscote Grove Road, is to be at low level. The centre of the site will be occupied by an extensive covered car park, sunk five feet below general ground level and containing its own internal system of roadways. These roads will serve both car parks and give access to garages beneath each block of flats. Stairs and lifts will ensure direct contact with the buildings above. The large open spaces are designed to provide an area where the public can relax and be liberated from traffic hazards.

In the seven acres, architectural ingenuity has planned for a swimming pool, to be decked over with a mechanically operated floor when not in use, a conference hall to seat 2,500 delegates, with a translucent roof and also a cinema which, when not in use for Trade Conferences, would be employed as a small public cinema. The roof of the shopping centre is to provide garden terraces, allowing spaces to be used for sitting out for the restaurant and promenading during intervals in the conferences, under sheltered conditions. The centre shopping area of Weston is on either side of the High Street, about 300 yards from Oxford Street. The present proposals are likely to influence this situation, as redevelopment will result in a resident population within the site of about 900 people, including hotel guests. In addition, the public buildings will attract substantial numbers of people, especially the Conference Hall. All the shops will be approached under cover. There is to be a square, having on the outside four wide covered arcades, backed by shops and through the centre, an arcade or concourse, with shops on both sides. This will give access to the Conference Hall, restaurant, cinema and bowling alley. At present there is no provision in Weston for the latter-mentioned American craze. The plans thus include a bowling hall with 24 lanes.

Mention, of course, has been made of the fantastic holiday crowds which Weston attracts and for this reason it sports 325 hotels and boarding houses. Evidence, however, indicates a national decline of the small unlicensed hotels and a corresponding gain by the larger hotels, with their wider range of service and amenities. In Weston most hotels are small and boarding houses are more numerous. It is thus obvious that the present pattern of Weston must change, either towards a more modern form of holiday accommodation, or a reduction in the holiday trade in favour of other forms of employment. But there are two main factors which indicate that a prosperous future lies in a modernised holiday industry. The first is that national prosperity (you have never had it so good!) is resulting in greater leisure and higher wages, and in particular, the general adoption of holidays with pay. Secondly, Weston is very favourably placed geographically, not only because of the attractions of the surrounding country and sea, but because the town is near the routes from the Midland industrial centres to the holiday areas of Dorset, Devon and Cornwall. This important point is aptly illustrated by Weston's nickname of "Birmingham-on-Sea". If, therefore, the number of people who tour by car increases at the expense of a traditional holiday, as is decidedly the trend at the moment, Weston is likely to gain, particularly in view of the projected motorway linking the Midlands to Exeter via Bristol.

Circumstances appear, therefore, to justify the inclusion in the development scheme of a large hotel. This is planned on the sea front as a 22-storey tower, and it would form the most conspicuous building in Weston by far. To prevent a building of such height having too massive an appearance, the tower is designed to be as slim as possible, having a circular plan with structural elements emphasising the verticality of form. The tower form also assures magnificent views from the bedrooms, the majority of which have views of the coast and sea. Deliveries will be made, and refuse removed, under cover, at basement level, five feet below general ground level. This level will also accommodate the administrative offices, stores of all sorts, and cloakrooms. Bedrooms are to be arranged ten to a floor, with one maid's room per floor. All are to be double, with their own private bathroom and toilet, having a living area and recessed sleeping area. Some rooms will have an additional all-glass bow-front for sun and view, adding some 75 square feet to the basic 230 square feet. On the centre of the roof will be a raised platform, 230 feet high, where the breezes are bound to be as fresh and rich as when they left South America! Being centrally placed and with views of the sea, the site is also ideal for flats. There are to be five, twelve-storey blocks, of these with a mixture of one-, two- or three-bedrooms. Their areas are to be 785, 1,010 and 1,300 square feet respectively.

Mention has been made of the first Urban Council of 1895 providing a Public Library and Museum. This Victorian red brick building, at the eastern end of the Boulevard, although recently modernised and supplying excellent services, is still inadequate for the expanding 40,000 population of Weston. It is thus planned to include a three-storey building with entrance hall, offices, cloakrooms, reference and reading rooms, record library and a photographic section, for the purposes of a new library. The building is to be sited in a very conspicuous position adjoining the Town Hall and

has been designed not only to provide spacious and architecturally interesting interiors, but also to form an imposing element of the civic group. The existing Town Hall will form the eastern limit of the site, having direct access to the railway station. It is to be extended by 20,000 square feet.

The cost of this gargantuan scheme is estimated to be in the region of £3,805,000, of which £700,000 is for Council buildings. The superlative hotel will account for some £600,000. Little wonder many people are leaving the borough to evade rates!

“Weston-super-Mare stands today unashamedly modern, rather like a gleaming, chromium portal, inviting entry to all the pleasures the West Country can offer”. This is, of course, a quote from a guide book, but even the most conservative of us must remark on the ability of Weston to cater for all classes and tastes. Few towns are more picturesquely situated than that part which climbs Worlebury Hill, especially in early summer, when the foliage of its abundant trees, the colour of laburnums, the sweet scent of May and the golden glory of its sunsets, make it one of the most desirable towns in England.

The keeping of Tropical Fish

by P. BAINES

Chairman, Weston-Super-Mare & District Aquarist Society

Tropical fishkeeping is a hobby which gains more and more followers every year. These undemanding pets, from the world's warmer regions, provide us with an ever-changing panorama of colour and add a touch of the exotic to any home.

After deciding to keep these beautiful creatures, the first requirement is, of course, a tank to keep them in. Many types are available; perhaps the most common is a rectangular one of dimensions 24 in. × 12 in. × 12 in. A heating system is also required because tropical fish must be kept in water at a temperature of approximately 75 degrees fahrenheit. Suitable heaters and thermostats are available, which are both reliable and inexpensive. These are usually of the immersion type. With this basic equipment, together with a thermometer and about 20 lbs. of gravel (called compost), all obtainable from pet stores, one can make a start on this most fascinating of hobbies. A tank cover is also desirable, with electric lamps, of low wattage, fitted to illuminate the tank and to provide sufficient light for good plant growth.

The tank should be placed on a sturdy piece of furniture or stand, for a tank of the dimensions given weighs about one hundred-weight. Before putting the compost into the tank it should be thoroughly washed, until the water running out of it is absolutely clear. The compost can then be put into the tank and it is best to do this so that the compost is about 3 in. deep at the back and only 1 in. deep at the front. This gradient causes the sediment to collect at the front and this can then easily be syphoned off.

The tank can now be decorated with rockwork, placing the rocks so that the fishes will not be hidden from view and making

sure that there are no sharp edges on the rocks, on which the fishes might injure themselves. The tank should now be about half filled with water (tap water is suitable in most areas) and the heater and thermostat put in place and connected up.

Now is the time to really show one's artistic ability by planting the tank and trying to achieve a natural effect. This, of course, is a matter of personal taste. Care should again be taken that no large plants are placed in the front of the tank in such a way that they hide the view of the fishes. Any of the plants listed are suitable, but it is found that, in practice, only about four to six different varieties of plant will flourish together in one tank.

Vallisneria spiralis (straight vallis) and *Vallisneria torta* (twisted vallis) are both grass-like plants which look very pleasing when planted, say along the back of a tank. *Sagittaria natans* is another similar plant, but will not generally grow with vallis in the same tank. Giant hygrophila forms a nice centre-piece and Ludwigia, Cabomba, Ambulia, Water Wistaria, to suggest just a few, are all attractive plants.

After planting, the tank can then be filled to the top and the cover fitted. The lights should be left on for about eight hours per day and, with the size of tank mentioned, two 25-watt lamps should be sufficient, if the tank gets a certain amount of daylight. The actual amount of light required can only be found by experience; generally, if the tank glass gets a green coating (algae), too much light is being given and, if the plants do not grow very well, or go brown in colour, not enough light is generally the reason. It is best to leave the tank with its plants for about 1-2 weeks before introducing any fish, to allow the plants to get a good start, and allow the tank to "settle down".

The aquarium is now ready for the introduction of the fishes. The selection of fish is, of course, a matter of individual taste. Some people prefer a tank of fishes of one or two varieties, whilst others prefer as many different fishes as possible. The latter seems to be the more popular and such an aquarium is called a community tank. In stocking a community tank it is advisable to stick to fishes which grow to more or less the same size. It is usually disastrous if one tries to keep Neon Tetra, which attain a length of one inch with, for example, Oscars, which attain a length of over twelve inches. When one bears in mind the fact that, as one eminent aquarist put it, "the best food for fish is fish", the reason is obvious! The following list is given as a suggested community:

Trios of the following: Neon Tetras, Glowlights, Beacons or Head and Tail Light fish, Cherry Barbs or Chequer Barbs, White Cloud Mountain Minnows, Penguin fish, Zebra fish.

All the above fishes are very beautiful, active and undemanding. Neon Tetras, really, deserve a title such as "living jewels". All of these fish attain a length of between one and one and a half inches.

There are, of course, thousands of other fish to choose from but the ones listed are easy to obtain and relatively cheap. Certain fishes should be avoided. The Cichlid family, in general are not to be trusted and usually pull up plants and the majority of Cichlids grow to over four inches long.

The beautiful male Siamese Fighting Fish can be kept, if one male alone is kept with other fishes; two male fighters will, however, fight often to the death. The majestic Angel fish can be kept with smaller fish until it gets too large. Tiger Barbs, although lovely fish, have a reputation for “fin nipping”.

The question which arises is as to how many fish can one put into a tank. As a rough guide, there should be 8 inches of water surface area per inch of fish in the tank: i.e. a 24 in. \times 12 in. \times 12 in. tank can hold approximately 288 divided by 8=3 dozen fish, each one inch in length, or 18 fish, each two inches in length.

The fishes should be fed little and often; a little three times per day is much better than a lot of food once per day. Tropical fish food can be obtained in small tubs from pet stores and a small tub lasts for a considerable time. The tendency, when one starts keeping fish, is to over-feed them. A good rule is that, at any one feeding, if all the food is not eaten in five minutes, too much is being given.

If a tank is overfed, then the food decays on the bottom, the tank begins to smell and the fishes gasp at the surface and the whole thing soon looks in a sorry state. So being over-generous with food is being very unkind to the fishes.

There are several valuable additions to the diet, which will help to keep the tank inmates happy.

Clean chopped earthworms, live tubifex worms (available from pet stores), live daphnia (to be found in stagnant ponds), white worms (which can be bred), etc. are desirable foods, but not essential.

Perhaps the most interesting part of tropical fishkeeping is breeding them. This, of course, requires extra equipment, but the interest and fascination of this part of the hobby easily repays the expense. A fact which few people seem to know is that quite a number of fish, Guppies, Platies, Mollies, etc., give birth to live young. Another family of fishes, the Anabantids, including the Siamese Fighting Fish, build a nest of bubbles on the water surface, the male squeezes eggs out of the female, during a nuptial embrace and puts the eggs into the nest of bubbles, where they hatch in about two days. There are many other unusual methods of reproduction employed by fishes, which can provide us with hours of interest and there are many species which have never been bred in captivity, thus presenting the serious fish breeder with a never ending series of challenges.

Tropical fish are extremely hardy creatures, contrary to general opinion, and there are very few diseases to which they are prone.

The intending aquarist is strongly advised to go along to a meeting of his local Aquarist Society, where he will find the answer to any query, and often obtain fish, plants and equipment.

It is hoped that this article has “whetted the appetite” of intending fish keepers and any aquarist society would be delighted to welcome prospective members.

**SAFE FAST CHARGING
BATTERY SERVICE
— ONE HOUR —**

—You have no need to move very far
from the camp.

RING — 35
STARTER BATTERIES from
£3—1—4

KNIGHTCOTT GARAGE

(R. Belbin)

BODY REPAIRS : SERVICING

Tyres All Sizes

CLEVELAND PETROLS

BANWELL : Tel. 35



THE R.A.F. BENEVOLENT FUND
needs

£600,000

a year

to continue assisting cases arising
from casualties in war as well as
from flying accidents and ordinary
distress in peace.

Please send donations to :—

**Hon. Treasurer, R.A.F. BENEVOLENT FUND,
67 PORTLAND PLACE, LONDON W.1.
TEL : LAN 8343**

Space kindly donated by :—

C. Parrott and Sons Ltd., Wholesale Fruiterers, Drove
Road, Weston-super-Mare, Somerset.

TRAVEL BY—

EMPRESS COACHES W.s.M.

Phone 133

EMPRESS COACHES Bristol

Phone 20650

**1 LOCKING ROAD,
WESTON-SUPER-MARE**

Special Quotations for Private Parties.

TOURS DAILY to—

Cheddar Caves Torquay
Lynton and Lynmouth
Weymouth, Bournemouth, Etc.,

Send P.C. for List of ALL TOURS.

VICTORIA

School of Motoring

**VICTORIA GARAGE (WESTON) LTD.
ALFRED ST., WESTON - SUPER - MARE**

**TRIUMPH HERALD
DUAL CONTROL CARS**

R.A.C.

REGISTERED INSTRUCTOR

**MEMBER OF INSTITUTE OF
ADVANCED MOTORISTS**

CALL OR 'PHONE 1450 W.S.M.

Roving Reporter in a 'Z' Car

Tearing myself away from the Square Box one night, I decided to see for myself what the work of a Police patrol car crew is really like. I was fortunate enough to secure the willing co-operation of the Somerset Constabulary who permitted me to accompany two police officers during the whole of their eight hour duty in a car on Saturday, 9th May. Our car, a Ford Zephyr, was known as QH 7 and was manned by P.C.s John Rees and Cyril (Dusty) Miller.

The following is a diary of the events which we encountered on the 2 to 10 shift on 9th May.

- 13.45.** P.C.s Miller and Rees reported for duty. Before leaving the station they signed on and collected their messages, which consisted of details and photographs of wanted and missing persons and stolen or suspect vehicles. This was followed by a general inspection of the car and its special equipment.
- 14.00.** We left the police station and drove into the town with P.C. Rees at the wheel. When we reached the sea front Dusty called control, which is at Taunton, and reported that QH 7 was mobile.
- 14.20.** Whilst driving along Orchard Street we spotted a man riding a bike with no rear reflector and no glass in his rear lamp. He was stopped and Dusty had words with him and checked the brakes on the bike. This was done in the interest of road safety.



- 14.25.** When we were approaching the Odeon Cinema we were stopped, and asked if we would move on a drunk, who was hanging around the public conveniences, at the floral clock. John and Dusty searched around for him and found him staggering about in the gent's and, after a little coaxing, amid shouts of, "I'm the fly weight champion of the world", the drunk moved on his way.
- 15.00.** After being passed by a black Standard van, at speed, on the A.370 Bristol road, we kept an even distance, as much as possible, behind and checked his speed over half a mile on the chronometric speedometer. He was doing between fifty and fifty-three, so it was decided to stop and advise him. Just past Congresbury, he drove into a filling station, so John drove past and stopped beside Brockley fruit stall to await his arrival. Dusty stopped him, examined the van and driver's particulars and gave him suitable advice.
- 15.20.** On the A.38 near Redhill we passed a motor cyclist who was wearing no helmet, so Dusty called control to make sure that it had not been stolen, and checked up on the registration of the bike. The reply was negative, so we did not stop the motor cyclist.
- 15.27.** A random check was carried out on two soldiers driving an old Morris Oxford. They were in the clear, and were allowed to proceed.
- 15.30.** Dusty carried out a check on a hitch-hiker at Churchill Rocks on the A.38, just in case he may have been a missing person. He was a cellulose worker, had a broken left leg, and was hitching to his home near Bridgwater. We left him and called Police Records giving his name and description and, ten minutes later, they replied stating that he was neither wanted nor reported missing.
- 15.45.** Near Sidcot School we spotted a car, parked on a dangerous corner, marked with unbroken double white lines. Making use of our loudspeaker, Dusty asked the driver to remove the car as he was creating an obstruction. The driver stopped us and said his car was broken down, so we parked the Zephyr on the grass verge, got out, and gave him a push off the corner and onto the verge further up the road.
- 15.52.** Near the Lamb Hotel at Weare we passed a bright orange fork lift truck, which was being driven from John-o-Groats to Land's End, as part of a sales drive for the Yale and Towne Company.
- 16.07.** Approaching Highbridge, we stopped a grey Austin van and Dusty checked the driver's papers and did a road-worthiness check of the vehicle. The occupants, three young men driving from Birmingham to Torquay in search of seasonal work, were allowed to proceed.
- 16.15.** A message was received saying that a Tiger Cub motor cycle had just been stolen from Taunton.



16.30. Whilst driving along Burnham-on-Sea promenade, we spotted a grey Ford van with a buckled rear nearside wheel going on a rather unsteady course. Giving the driver a “wake up” ring with the bell, we pulled up in front of him and Dusty approached and spoke to the driver about the way he had been driving. It appeared that he had been too busy watching the scenery to be bothered about the road. He was cautioned and allowed to go on his way.

17.15. We found an Austin Westminster parked on the A.38 near Edithmead. We located the driver on a caravan site nearby and asked him to take his car off the main road, as it was obstructing the fast-moving traffic.

17.22. Back in Weston-super-Mare, we were stopped by two elderly ladies outside the Rozel Hotel at Knightstone. They reported a very distressed looking dog they had seen charging around the beach beside the Grand Pier. We drove down and stopped outside the Winter Gardens and Dusty walked onto the sand and had a look round. He returned and told us it was just a donkey man’s dog having a whale of a time on the sand.

17.40. Tea-time at last. We went back to the police station and had a brew-up in the tea bar chatting with the crew of another car coming off duty. We were also visited by Inspector Hughes who is the Patrol Inspector from Headquarters in Taunton and is an ex-fighter pilot. He told us about the trials of the new Lotus Cortina police cars and gave us a few good laughs before we finished our tea.

- 18.25.** Tea break over and back on patrol again with Dusty at the wheel this time.
- 18.50.** We laid up in a side turning near the sea front, at the beginning of a measured mile to deter and detect speeding offenders. We went after one chap in a Vauxhall and timed him over the mile, with a stop watch, but he did not exceed the limit.
- 19.55.** After leaving Weston, Dusty cruised around the country roads for a time and John decided to go over to Sandford village and investigate a report of speeding there. When we arrived, Dusty backed down a narrow lane and waited there, but without result.
- 20.35.** Our first call came through, telling us to go to a public house near Weston town centre. A group of Apprentices from Locking had got into a little trouble over the location of the gents' toilet. It appeared that someone had mistaken the beer cellar for the "Gents". After the boys had told their story, everybody went off reasonably happy, except for the publican.
- 21.00.** On Bournville Estate, we stopped a teenage motor cyclist, for approaching a road junction in a careless manner. John left the car and gave a few words of good advice to the person concerned. Afterwards, we followed the rider round to his house, where he collected his licence and insurance certificate and showed them to John, after which he was allowed to go on his way.
- 21.15.** Control reported an accident on Milton Road.
- 21.18.** We arrived at the scene of the accident, which involved a boy on a motor cycle and a girl on a push bike. The girl had cycled across the path of the motor cycle and, in swerving to avoid her, the boy hit a tree. The ambulance had already taken the two of them to Weston General Hospital, so John and Dusty made a few enquiries and took notes, relating to the circumstances of the accident and the extent of damage caused. After this, we drove to the hospital to see the casualties.
- 21.53.** While we were at the hospital, a call came through telling us to locate and intercept a blue Ford Consul, which had been involved in a hit and run accident at Flax Bourton and was heading for Weston.
- 22.02.** A correction came through stating that the hit and run car was heading for Bristol and not Weston.
- 22.10.** We arrived back at the police station where the car was put in its garage and P.C.s Rees and Miller reported to the duty sergeant, signed off, and crept home to their wives.

What became of me? I had a smoke and a pint and crept off home too.

One thing to remember—the boys in the police patrol cars are not out to get you, as a lot of motorists seem to think; they are there for your guidance in road safety and other matters, and, to keep the roads safe, they need your help just as much as you need their's.

I would myself, and on behalf of the *Locking Review*, like to thank the members of the Somerset Constabulary for their assistance in enabling me to produce this article.

Beethoven, Berlin & Beatles

(*The Radio Magazine* Record Library)

by C/T WAINIKA

Do you remember “The Loveliest Night of the Year”? That was No. 3 in 1952, the year in which the modern Hit Parade Charts began. Do you remember Doris Day’s “Bewitched”? That was the first Hit Tune to be played in *Radio Magazine*—in edition No. 8, two years earlier.

The *Radio Magazine* Record Library was born on the 22nd February, 1950, at Compton Bassett—more or less by sheer accident! The Station magazine was the *Mercury*, and printing difficulties had created a serious complication. The January 1950 edition would not be available until February, and the Editors had promised to award prizes for a crossword competition. So, they resorted to C.F.N. (‘alas poor Yorick!’), the Station broadcasting system, for assistance. Naturally, although the programme would only last 15-minutes, it was thought advisable to include a little supporting music. One of the Editors was a funny man and insisted on inserting comic remarks. The other Editor tried to maintain some semblance of order—and he has been doing that with *Radio Magazine* Record Library ever since. Anyway—to cut a long story short—from that germ of an idea sprang *Radio Magazine* and edition No. 1 went out on that cold February night. We can tell you that there were approximately 15 records in the programme, that it lasted for 45-minutes, and there was a dramatic monologue with “London Fantasia” as the background music. We also believe that “Boutique Fantasque” was the opening theme. But that is all we can tell you—for all the copies of the script were surreptitiously “lifted”. That first edition and Nos. 42 and 43 (where frantic replanning had to be made at the last moment, because of a fire) are the only editions that have not been fully recorded in the four volumes of the *Radio Magazine* Diary in fourteen years of programmes. Then a funny thing happened. . . . C.F.N. kept on breaking down during 1950. So, on the 21st January, 1951—with edition No. 24—*Radio Magazine* went live, before an audience, and it has been “Lively” ever since.

The original concept of *Radio Magazine* was to cover all aspects of entertainment, but there were special occasions and special programmes. In the early '50s, there was a Concert of Light Music on Good Fridays (for we also kept running for the duty staff over Grants). The Station Dramatic Society had joined in with sketches and our own version of the famous “I Want to be an Actor”. There were contrasts too! We sometimes had to lock the doors, because 300 was the maximum audience the Naafi Club Lounge could hold;

yet, when edition No. 79 was presented (the only entertainment on the Station in that week) on 11th February, 1952, as a special tribute to the memory of King George the Sixth, only one man attended (the Entertainments Officer who had obtained special permission for the programme to be presented felt very, very bitter about that!) But, as *Radio Magazine* progressed from Compton Bassett to Germany, then back to Compton Bassett, it was becoming evident that the field of entertainment was too vast to be covered by one programme. With edition No. 221 on 14th September, 1959, two important things happened; it was, by the way, the first Locking edition. First, the Hit Parade started taking up the major part of the programme; and second, *Radio Magazine* went STEREO! This was a major move on our part, for Stereo had only been generally introduced the previous year, and it was still somewhat of a novelty. Even more daring, it included our own stereo tape recordings—for we had been using tape since 1954. Then *Radio Magazine* burst at the seams, and, after edition No. 254 in July, 1960 came the first edition of “DISCorner” in August, 1960. Now, the new baby could look after the Pops while the grand-daddy could look after the rest. But, even that was too much, and in October, 1962, *Radio Magazine* Concert Hall took over the Classics with a Wagner concert.

Which brings us to the present day. *Radio Magazine* is rapidly heading towards its 400th edition, “DISCorner” has recently celebrated its 100th, and “Concert Hall” has passed its 50th. To keep track of everything, the *Radio Magazine* Record Library has been divided into eleven divisions, and they include “Studio Two” which makes occasional O.B. recordings, a Film Division which is building up its own 8-mm. films for future presentation, a Research Division to keep the facts straight (and this ranges from Pop Trade papers to the *Encyclopaedia Britannica*) a Religious Division which presents as its major feature “The Living Bible”, and—in the near future—a new programme, “Jazz Joint”. Keeping a watchful eye over the lot is a twelfth division, the Statistics division, the pride and joy of this department being a series of Hit Parade Charts, specially analyzed from all the Trade papers and issued weekly non-stop since February, 1957.

The Library is all private property—but it is devoted to Service entertainment. Two Stereo record players, a Stereo tape recorder, two battery recorders, film camera and projector, and at present over 500 records, including 300 very precious 78's, 100 E.P.'s of both 45 r.p.m. and 33 r.p.m., and 100 L.P.s, most of the latter being in Stereo.

The only thing we seem to lack nowadays is big audiences. *Radio Magazine* is presented on Mondays in 3 Area N.A.A.F.I.; “Concert Hall” on Wednesdays at the same place and time (1930 hrs.) and “DISCorner” is presented in the P.M.U.B. Clubroom on Fridays at 1900 hrs. But, never mind, we keep going for the few. We once used our slogan extensively—“News and Entertainment for the Welfare of the Service”. We sincerely hope it still applies.



BY APPOINTMENT
TO HER MAJESTY THE QUEEN
GOLDSMITHS & CROWN JEWELLERS,
GARRARD & CO. LTD, LONDON

Silver . . . *by* GARRARD

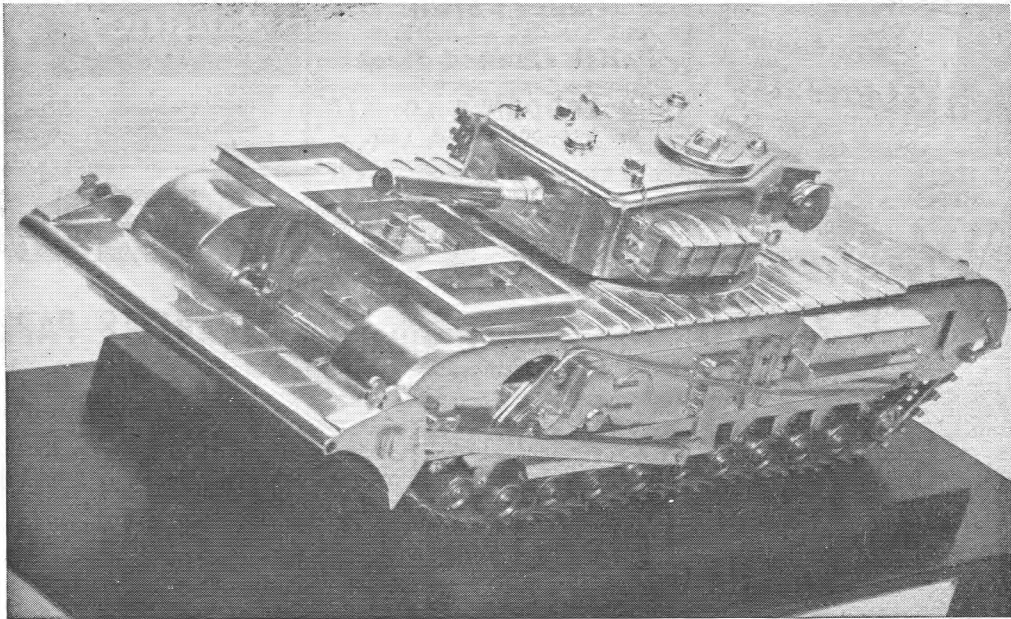

The military department specialises in making presentation plate, mess plate, cups and other trophies : these may be to your own design, from a picture or sketch, or we can produce designs to suit your requirements.

GARRARD The Crown Jewellers

112 REGENT STREET W1 • REGENT 7020



THE FOLLOWING FIRMS SUPPORT SERVICE JOURNALS



Glenville
CUSTARD POWDER
BUY Goodness
BUY Glenville

"YORK" BRAND

Canadian Salmon
Canned Vegetables
Canned Fruits
Polish Canned Meats

JOHN LOUDON & CO. LTD.
No. 1 LONDON BRIDGE, S.E.1.

ATTENTION!

*the best meals are eaten
with*

**green label
chutney**
INDIAN MANGO



One of Sharwood's
quality food products

Refreshes after work, travel and sport

Wright's
COAL TAR SOAP
IDEAL FOR TOILET BATH AND NURSERY

SMITHS

have crispness

in the bag!

Smith's Potato Crisps Limited,
Great West Road, Brentford, Middlesex.

RIZLA

CIGARETTE PAPERS



Britain's Best Canned Foods

ALSO PROPRIETORS OF

Friar Tuck

Superior Canned Meats

The only way
to find out if
Barter & Dobson
Regal Fruit Drops and
Everton Mints taste
as good as they look
is to TRY THEM!

HALL & EARL LTD.

'Puritex' Mills, Tudor Road,
LEICESTER

Manufacturers of Underwear in Wool,
Cotton, Art. Silk, etc Branded "Puritex"
'Grams: "HANDEL" 'Phone: 23105'6'7

T. M. BIRKETT,
BILLINGTON
& NEWTON LTD.
HANLEY & LONGPORT
STOKE-ON-TRENT

Specialising in
NON-FERROUS CASTINGS
OF EVERY DESCRIPTION



**DRUMS
& BUGLES**

CONTACT
GEORGE POTTER & CO.
(MUSICAL INSTRUMENTS LTD.)
ALDERSHOT
EST. 1810 PHONE: 22100

ONYX
adds
elegance
to
grooming



LENTHERIC
LONDON · PARIS

O.K.

THE SAUCE THAT DOES YOU GOOD

For Your Enjoyment
Callard & Bowser's
Celebrated "Thistle Brand"
BUTTER-SCOTCH
Famous since 1837

The Role of the Computer in Banking

by G. B. HAGUE

Manager of Lloyds Bank's Research and Development Department

Although the introduction of computers into the field of banking was slower in starting than it was in the commercial field, considerable advances have taken place in the past two years. All the major banks and a number of the smaller institutions now have computer installations. In one case, that of Lloyds Bank Limited, five separate computers are already operational and others are due for delivery in the next twelve months.

The majority of the installations are at present employed in the handling of customers' current accounts, but following the recent technical advances in the ability of electronic computers to "read" character symbols on documents, the banks are now installing additional equipment, often associated with computers, to sort and list the vast volume of cheques that are in daily circulation throughout their many branches.

The processing of current accounts and the sorting of cheques calls for equipment capable of handling vast quantities of data which, as it is originated by the customers of the banks when they write cheques and pay in credits, must first be converted to a machine language capable of being interpreted by the computers. In many ways computer operations in banks differ from those in commercial and scientific installations: the use of computers in banks entails handling this mass of input data every day. It is necessary for the banks to have up to date information readily available in a printed form for presentation to their customers, and this calls for high speed printing on a relatively large scale. From a purely mathematical standpoint there is little call for computer techniques but the capabilities of the machines are necessary for co-ordinating this input interpretation and output printing.

The banks have collectively agreed to adopt the American Bankers' Association "style E-13B" characters. Cheques bearing these characters printed in magnetic ink are now in general circulation throughout the country. In some banks over 50 per cent. of their cheques are so encoded. The magnetic characters indicate the bank, the branch, the cheque serial number, and the drawer of the cheque.

There was no need for the banks to agree on any standard form of computer, and the choice of equipment has been left to each individual bank. The result is that the various banks have installed a wide variety of computers and associated systems, their only common factor being the acceptance of the common machine language.

The reasons for the introduction of computers into banks are basically economic. Banks are in a highly competitive business and are anxious to provide as efficient a service to their customers as possible but they are naturally concerned to operate the service on a profitable basis. Although it is doubtful whether many of the

existing computer installations can be proved to be operating economically, there are a number of factors that should be taken into consideration in assessing their economic justification. The number of customers' accounts, as well as the daily number of transactions by established customers, are both increasing. The availability of office accommodation and of trained staff is a limiting factor in the efficient expansion of banking business and the introduction of centralised bookkeeping by the use of computer techniques enables the branches to be relieved of much of the daily drudgery of ledger posting. Accommodation at present used for housing conventional ledger-posting equipment is released when the customers' accounts are handled centrally on a computer and is therefore available for increasing counter facilities without the need for purchasing or renting additional premises.

With one exception all the banks are at present operating computers associated with magnetic tapes. The exception is Lloyds Bank who have adopted the principle of "on line" processing and have been successfully operating a "Random Access" system for the past two years. The method of preparing input data varies from bank to bank and the method adopted is often dictated by the choice of computer. The means of input most commonly used is punched paper tape prepared on wired adding or accounting machines and as a by-product of a necessary listing operation, but both punched cards and the use of magnetically encoded documents are also in everyday use. Where there are large concentrations of data to be converted to machine language it is probable that punched cards are still the most economic method and require less effort in control.

Unlike banking practice on the Continent and in the U.S.A. it is an established principle in Britain for the banks to take their service to their customers with the result that each major bank has set up a large network of branches throughout the length and breadth of the country. Most of these branches are relatively small.

The economic use of computers necessarily requires a high concentration of accounts and because of the policies of decentralisation of banking offices it is necessary to set up a considerable telecommunication network so that the daily entries in respect of these scattered offices can be processed on the central computers.

The extension of the use of encoded documents will, as far as cheques are concerned, meet this need to collect input data from the many branches of a bank because it will be possible to capture the data onto magnetic tape at the stage at which they are sorted in the Central Clearing Departments. There remains, however, the problem of bringing in each day to the Data Processing Centre the remaining customer transactions—credits, cash withdrawals, dividends, etc. Although this is at present effected either by physical movement of the documents or by the use of paper tape it is evident that there is scope for the development of "on line" processing techniques whereby it would be possible for a distant branch to communicate direct to a central processor, using merely a simple adding machine connected to the central computer by a telephone line. There is also, of course, a need to develop satisfactory and economic means of relaying information from the computer to the branches.

The use of computers in banks has now become established practice and it is probable that the next few years will see the adoption of computer accounting with associated document-reading and communication systems as the banks' standard method of accounting. As techniques develop the use of computers may well extend to cover the more specialised work of Trust Accounting, Foreign Exchange Control, Share Registration, Staff Records and Pay. The banks are in fact on the threshold of a new era in accounting techniques made possible by the introduction of computers and associated data processing.

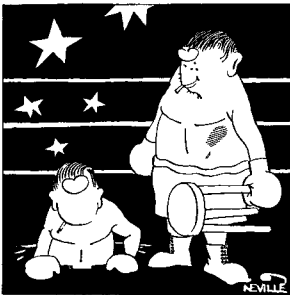

Boxing

1963/64 SEASON

The season has been a good one marred only by losing the Sigris at Halton in October.

In November the team went to R.A.F. Henlow to defend the Lord Wakefield Trophy, won in 1962. This championship is open to all stations in the United Kingdom. After two days battling, six of our team won their way through to the finals. Rather strange to say this, but it was unfortunate for Locking that the six won their finals: Bennett, Tabor, Hoon, Manning, Norton and Larter all being clear-cut winners. The unfortunate side of it is that Locking had already won the Trophy before the finals were contested, and once a Wakefield champion, one cannot compete again, so this year these boxers will follow their understudies' progress very carefully from the "touch line".

Several local tournaments were held, finishing with a good win at Bath, where two fights are worthy of mention. A.A. Buckel of the 104th Entry—a novice boxer who showed great courage in a close contest against a more experienced boxer—by his aggression got the verdict. In the heavyweight bout C.A.A. Larter, 100th Entry, boxed L. Edwards, the Gloucestershire representative. Trainer Percy Parkes, I must say, looked more apprehensive than Larter before the opening round, however Larter beat his opponent on points, in a very decisive way.

One record which was set by Locking was that four apprentices were selected and boxed for the T.T.C. Team. They were A.A.s Bennett, Tabor, C.A.A.s Manning and Norton and their contribution helped T.T.C. to win the Inter-Command Championships.

M. M.

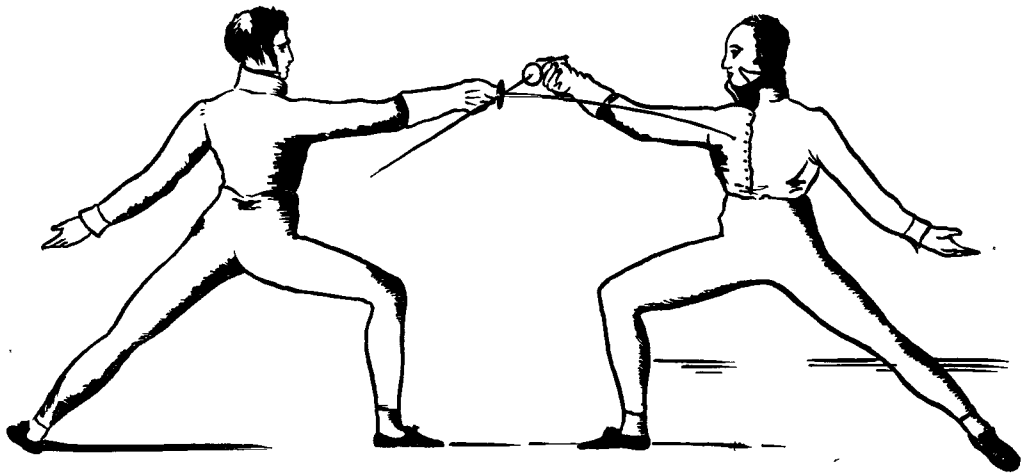

THE TIME IN OCTAVE

COPY OF ORIGINAL PRINT FROM 'THE ART OF FENCING' BY GEORGE ROLAND
PUBLISHED 1823

Speaking of Hairdressing . . .

*Ladies Hair Stylists
Mens Hairdressers
Wigmakers*

Our Wigmaking Department (incorporating Lloyd Wigs Ltd.) has a large output of Wigs, Wiglets, Hair Pieces, Switches, some of which are sent to all parts of the World.

Let us design a special Hair Piece for your own individual requirements.

Lloyd & Osborn Ltd.

The Boulevard : Weston-super-Mare

Telephone 3522 (2 lines)

— Contracting Wigmakers to the Ministry of Health —

The History of Fencing

by FLIGHT LIEUTENANT D. E. WARREN

PART I

Fencing today is an art and a sport. Only two hundred years ago it was a great deal more—it was a means of staying alive. Strangely enough it was the invention of guns and gunpowder which introduced skill into the use of swords.

The earliest swords were merely extensions of the human hand. There was little or no skill in their use until the rise of the Roman Empire, which was largely won by the Roman short sword. This was probably the first sword to be mass produced to exact standards of workmanship. The Roman legions were trained to use their swords to both cut and thrust. They could only defend themselves, however, by their shields and body armour.

As the use of armour grew more widespread, swords became heavier in order to cut through the mass of steel in which knights were encasing themselves. By the end of the 14th century the situation was becoming ridiculous; knights had to be hoisted by crane into the saddle and swords were five feet in length and used with both hands.

Quite obviously it was impossible to develop much skill using a sword weighing twenty pounds whilst wearing armour weighing two hundredweight! It was at this stage that the invention of gunpowder led to the disuse of armour. It now became possible to make and use a lighter sword and so the rapier came into being.

The rapier brought about the development of fencing as a skill. Schools of fencing sprang up all over Europe. Most of these taught very crude methods because the rapier itself was a crude weapon. It was anything up to five feet in length and the only means of defending yourself was either to duck out of the way or to parry with a dagger held in the left hand.

In the 17th century, however, there was a change in the fashion of men's dress. Doublet and hose gave way to long silk topcoats and knee-breeches; the clumsy rapier gave way to the short, light court sword. This became known as the "small-sword" and, because it was light and convenient to use, made it possible for swordsmen to develop a skill and technique of their own.

The "small-sword" was the beginning of fencing as we know it today. The weapon was light and a man could both attack and defend himself without the use of armour or a dagger. Hits were made with the point only and it was regarded as an essential part of every gentleman's education that he became proficient with the small-sword.

Fast fencing with light swords involved the risk of danger to your opponent's eyes and face, even though the weapons were blunted for practice. Hits were therefore restricted to the body only and this type of fencing practice became hedged around by rules and conventions. The practice weapons became even lighter and eventually became the present day foil. But this was only possible after the invention of the mask about 1800. Even as late as 1823, as we can see from the illustration above, the fencers at the Royal Academy in Edinburgh were fencing without masks.

The conventions of the small-sword, and the restriction of target area, did not apply where duelling was concerned. The only criterion here was the ability to draw blood—"first blood" was the basis of most duels. Very few duels were fought to the death and honour was usually satisfied by the letting of a little blood. As there was no fixed target area and no conventions were required a new weapon was evolved about a hundred years ago. This was the "épée de combat" and was merely used blunt for practice and sharp when you were fighting in earnest. This weapon is still in use today as the "épée" and the style of fencing has changed little during the last hundred years.

Whilst the nobility made the small-sword fashionable, the ordinary people in this country still practiced fencing as a part of their normal lives. They used the "backsword", a development of the rapier and the heavier military swords. It is, perhaps, not generally realised that prize-fighting was originally fencing. Prize-fights were organised on a very large scale and, indeed, became one of the major amusements of the ordinary people. It was not until the end of the 18th century that fights with the fists were introduced into prize-fighting. This only happened because the then professional fencing champion, James Figg, was also the first English boxing champion.

The backsword itself dropped out of use but from it was developed the heavy military sabre. This weapon continued the cut and thrust principle of its predecessor but it was rather clumsy. The Italians, however, introduced the light fencing sabre about seventy years ago and this weapon rapidly became the fastest in use of all our modern weapons. Nowadays, sabre fencing is usually surrounded by many conventions but the weapon is still used for duelling, especially by student societies in Central Europe.

In this article I have discussed only the history of fencing in Europe. This is mainly because a much higher standard was achieved here than in any other part of the world. One of the really interesting mysteries in fencing is why Europeans fought with straight swords and everyone from Turkey eastwards with curved swords. It used to be said that this was the Cross of Christendom (the straight sword crossed by the guard) against the curved Crescent of Islam. The weak point in this theory is that the straight Roman sword and the curved Chinese sword were both in use many centuries before either religion came into being. We know quite a lot about the history of fencing but this is one problem that may never be solved satisfactorily.

Fencing today is an active sport, with well over a thousand clubs in this country alone. Fencers from all over the world compete at every level, including the Olympic Games. In the next article I will discuss the modern weapons and their use in competitions.

(Editor's Footnote: Flight-Lieutenant Warren, our Station Adjutant, is peculiarly fitted to write this very interesting history, as he has been actively concerned in fencing for many years. He started his fencing career as a schoolboy and later, during the period 1949-53, fenced for Edinburgh University and was awarded a Blue. At present he is Vice President of the Northern Ireland Amateur Fencing Union and, as many will know, also takes a very prominent part in fencing on this Station, both as a coach and as a member of our team.

A SUPREME TEST

The Fastnet Race is the supreme test for yachts and yachtsmen—and for ships' cooks and crews' stomachs too! About twenty yachts took Shippam's Chicken Supreme on the Fastnet Race last year. Here are just a few of the comments made after the race.

CAPREOLUS

"The best product of its kind I have used in 12 years cooking in small yachts."

DAMBUSTER

"Most certainly a satisfying meal, very good and no bother at all to prepare."

Mr. CUBE

"All the crew thought it was just what was required. Very satisfying and easy to prepare."

PELEGRINA

"Taste excellent. Good without embellishments."



If it was so easy to serve Chicken Supreme in a small galley at sea just imagine how good you'll find it for all your outdoor eating.

Chicken Supreme is the easiest way of eating chicken. The chunks of chicken in a delicious sauce can be served hot or cold; on their own, or with vegetables or rice; as a substantial main meal; as a snack on toast; or, when cooking is difficult, straight from the tin with salads, or as a sandwich filling. Whatever you are doing this summer, camping or sailing or picnicking, remember to take along some cans of Chicken Supreme. Easy to pack, easy to prepare, *easy to enjoy*, Shippam's Chicken Supreme provides a quick and satisfying meal for healthy outdoor appetites.

Shippam's

CHICKEN SUPREME—ONLY 2'9 AND 3'11

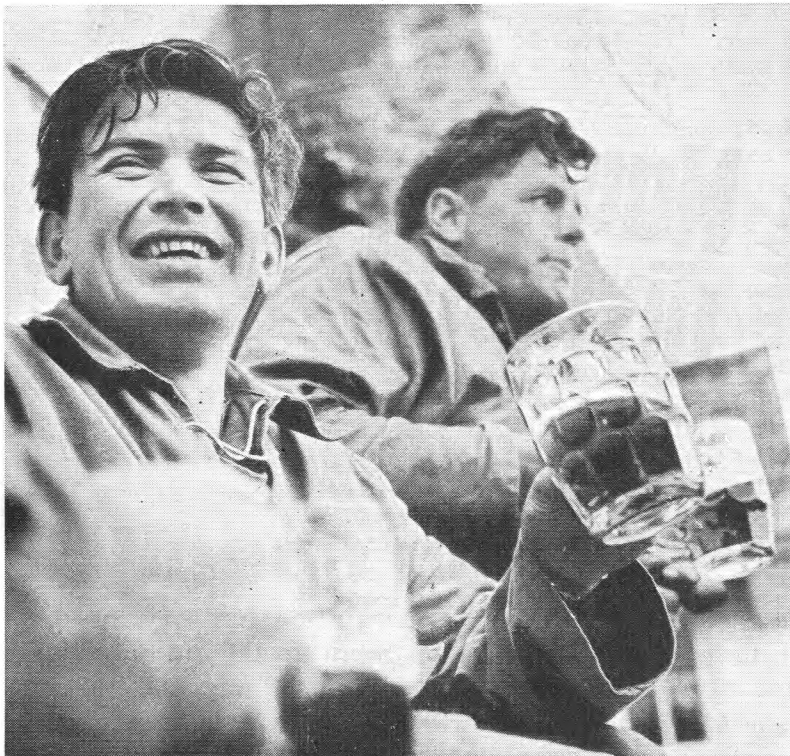

A pub in every port

Just brought the boat into harbour for stores and beer. Marvellous, that's how a pint of beer tastes after a six-hour thrash to windward. You know, we've a pub in every port from here to Mousehole.

When you're out to enjoy yourself—
BEER, IT'S LOVELY!

ISSUED BY THE BREWERS' SOCIETY,
20 UPPER BROOK ST., LONDON, W.1

FAMOUS DRINKS IN YOUR MESS		
 RUTHERFORD & MILES Old Trinity House BUAL MADEIRA	 WILLIAMS & HUMBERT'S DRY SACK THE SHERRY THAT PLEASURES EVERY PALATE	 Benedictine DOM <i>La Grande-liqueur Française</i>
 DUFF GORDON EL CÍD AMONTILLADO SHERRY	 HAWKER'S PEDLAR SLOE GIN JAMES HAWKER & CO., LTD. Estd. 1808 PLYMOUTH	 CHAMPAGNE Lanson BLACK LABEL
 Drambuie THE LIQUEUR YOU PREFER TO BE OFFERED	LEMON HART JAMAICA RUM. LAMB'S NAVY RUM. <i>Tia Maria</i> COFFEE LIQUEUR	These and all other famous drinks are obtainable through N.A.A.F.I.
 VINTAGE PORT MATURED IN THE WOOD NOVAL 1957	 BIANCO CINZANO RED · DRY	SOUTH AFRICAN WINES <i>The luxury you can afford for every occasion</i>



**BIGGEST
VALUE**

**Naafi
dividend stamps**



1/- for every £1 you spend!!!

✿ You exchange them for cash ✿ NAAFI stamps can be cashed anywhere in the world ✿ You can cash them quarterly — or save them up till you are ready

H.M. FORCES' OFFICIAL TRADING ORGANISATION



Art Club

Since October of 1963, membership has built up to eighteen and, with the aid of our instructress, interest and enthusiasm have been maintained. With the good attendance which is normal, everyone has been able to derive benefit and relaxation from the meetings on Tuesday evenings.

The Winter Session was spent entirely indoors and a number of works are now in the final stages of completion. One often wonders how a painting will turn out. From an idea, lines and shapes are placed on a canvas and colours are added from the different media available. After the final touches have been added, it is extremely satisfying to see the result on canvas. Many attempts can be made at expressing an idea through painting and, at last, all the members have found some theme with which they can persevere.

S.A.A. McLaren (99th) is usually to be found stretched out on the floor over his twelve square feet of water colour painting. At present he has completed a third but, when asked for a title, he refuses, on the grounds that a title might spoil his theme. Speculation runs high as to the final outcome!

A.A.'s. Facey, Hargest, Jones and Madge (105th) have started on a variety of themes and are at present experimenting to determine the various merits of oils and water colours. A.A. Taylor (105th) is contented with his bottles of spirits. To date, he has produced some commendable still life sketches of groups of bottles. He prefers the shape and form of this type of subject and he is assured that his models will remain still! A.A. Bradley (99th) has given his full support and is always to be found every Tuesday night behind his sketch pad.

A.A. Tyler (103rd) has almost completed an oil painting of the sun setting over the sea. It promises to be a worthwhile exhibit for the forthcoming Station Arts and Handicraft Exhibition. S.A.C. Harvey, one of our new members, is completely self-taught. His works are extremely commendable and a measure of his standard of achievement lies in the fact that he has been quite successful in selling his paintings. Corporal Ingram has only just joined, but has proved himself almost straight away by his charcoal drawing of the model at present sitting for the Art Club.

A number of family members also join in the activities and it is most pleasing to see that their contributions help to make the Art Club flourish.

What of the future? First in the calendar is the date of the Station Arts and Handicrafts Exhibition. A hefty contribution is always expected from the Art Club and the members are quite sure that they can provide such a contribution. To assist in any preparation, materials may be borrowed during the Grant Period. It is hoped that members will take advantage of this scheme.

At present, a model sits for posed figure drawings. This is a new venture and is proving to be very successful. It is hoped to provide a model at regular intervals for the coming Winter Session.

Congratulations to the Club Members for their contributions to one of the many activities of Station life.

OUR ICE CREAM VANS CALL REGULARLY AT THE CAMP

THE "FELLA" FOR QUALITY CATERING

FELLA'S

REGENT STREET, WESTON-SUPER-MARE

Telephone : 1755

Visit Our CAFE - RESTAURANT - SNACKBAR

MORNING COFFEE LUNCHEONS TEAS SUPPERS

MILLIERS

FOR

Radio

Television

Tape Recorders

Records

Reeds, Strings

Music

Pianos

Opposite the Odeon

DRY SHAVERS

Philishave . Remington . Ronson

WASHING MACHINES

Hoover . Hotpoint . Servis

OIL HEATERS

Valor Aladdin Rippingilles

H.P. TERMS & DEMONSTRATIONS

E. P. Leaver Ltd.

IRONMONGERS

WATERLOO STREET

WESTON-SUPER-MARE

Phone 916



Rugby Football Club

The 1963/64 Rugby Season started ambitiously by producing 1st and 2nd XV's from a total number of 33 players. The inevitable postings, injuries, etc., slowly but surely reduced this number to just sufficient to enable us to field one team. Regrettably, early in November, the 2nd XV's fixtures had to be abandoned and, were it not for the few loyal remnants of the 2nd XV, who remained as reserves and helpers, the season might have ended less successfully.

Results—Season 1963/64

<i>P.</i>	<i>W.</i>	<i>D.</i>	<i>L.</i>	<i>For</i>	<i>Against</i>
24	13	1	10	290	177

Yet, despite the handicap imposed by the shortages etc., the season can be looked back on as having been moderately successful when looked at in the light of the stiff opposition encountered in games against such teams as Bristol Police, Bristol University and Yatesbury. It was against each of these teams (away) that we suffered our heaviest defeats. Unfortunately only Bristol Police, of the three mentioned, came to Locking for the return game, where, this time, although we lost again, the margin of defeat was reduced from 16-0 at Bristol to 5-9 at Locking.

In contrast, Locking had some unexpectedly good wins. In particular, at home against Bristol Wednesday (25-6) and away against R.N.A.S. Yeovilton (6-14). The win against Bristol Wednesday is worthy of special mention. They draw their players from all over the Bristol area and beyond, and have, therefore, a great pool of talent available for all their games. A tough game was anticipated and the most we hoped for was a draw. But for once Locking was at full strength, weather conditions ideal, with every prospect of good open rugby. We were not disappointed. Locking opened the scoring after 15 minutes with a penalty awarded for a scrummage infringement just outside the Bristol 25 yards line. From then on Locking grew more confident and got steadily on top, out-hooking Bristol and getting the ball back to the Locking threequarters, who made the most of every opportunity to run and pass the ball. Time and again we were treated to the spectacle of the Locking three-quarters in full cry for the Bristol Wednesday line and, had it not been for some desperate defensive tackling by Bristol, the score could well have soared into the forties, in Locking's favour. As it was, all the Locking three-quarters scored and the maximum points were gained from the accurate conversion kicking by the Locking outside half.

In the 1st Round of the R.A.F. Cup, Locking were drawn at home against Compton Bassett. The game resulted in a win for Locking, 19 points to 6. Abingdon, our opponents in the 2nd Round, inflicted a narrow defeat on us (9-6) after a game remembered for excitement, toughness and, alas, too much foul play. Locking led at half-time by six points to three — a penalty in the first ten minutes and a try from a forward rush on the right-wing, offset by a penalty to Abingdon, just before half-time. After recommencing, Abingdon got the ball from a set scrum in their own half and managed to work it to their right wing, who scored a fine try in the right-hand corner, after a lung-bursting eighty yard sprint.

With the score now level, the play became over-robust, culminating in one of the Locking prop forwards having his ear bitten by *someone* in the Abingdon front row. With about ten minutes to go, Abingdon got the ball from a loose maul, found their left-centre who then side-stepped past a tired Locking forward, and covered the last fifteen yards unopposed scoring half-way between the goal-posts and the corner flag on the left. Thus the score became Abingdon 9, Locking 6; and Locking were out of the cup.

Now we look forward to a new season, which will bring with it some new laws. Let us hope that the new season will also bring with it many more players and enthusiasts, than the 33 gallants who registered at the beginning of 1963/64.

Canoe Club

by **PLT. OFF. J. A. BREMNER**,
Officer i/c Canoeing

This year considerable progress has been made in the Canoe Club, due mainly to the enthusiastic efforts of the club members and the excellent co-operation given by many sections on the station.

In January, menaced by approaching demolition the club moved its accommodation to a building near the sports pavilion in Farnborough Road. A few weeks later six members began strenuous training for the Devizes to Westminster Bridge Canoe Race, which took place during the Easter leave, and, with the help of unit funds, the club was able to purchase three glass-fibre two-seater canoes for use in this race.

The Devizes to Westminster Canoe Race is reputed to be the most arduous canoe race in the world and is a national event. The course is 125 miles long, made up on the Kennet and Avon canal and the River Thames, and has 77 difficult portages distributed throughout its length.

This year's Apprentice entry was the first ever to represent Royal Air Force Locking in this event.

The club members who competed were:

Crew 1: S.A.A. P. Sharman (99th) (*Captain*) and A.A. M. Shaw (99th)

Crew 2: A.A. A. Birchall (99th) and A.A. J. Hearl (100th)

Crew 3: A.A. D. Jones (102nd) and A.A. D. Sedman (102nd).

The three crews, despite their disadvantage in having less streamlined canoes, than nearly all other competitors, put up a splendid performance and the results were very satisfactory. In the Junior Class, 94 crews started and, out of these, only 51 finished. Of these 51 crews Jones and Sedman were placed 34th, Sharman and Shaw were placed 39th, and Birchall and Hearl were placed 40th.

It should be noted that the winning canoe, in 1959, was the same make as the ones used by our teams this year and its time for the course was only six minutes faster than that of our leading crew. However, canoe designs have advanced tremendously since then and it is hoped that, with the help of the Nuffield Trust, we shall have the sleek racing canoes for next year.



D.W.C.R. Team, 1964

Plt. Off. J. A. Bremner and S.A.A. Sharman, and A.A. Jones and A.A. Sedman competed in the Leamington Spa Canoe Race in April, achieving a satisfactory performance, and it is hoped that there will be entries for several other races this Summer.

S.A.A. Sharman led an expedition of 99th entry canoeists down 100 miles of the turbulent River Wye during the Whitsun Grant and they had some "hair-raising" but enjoyable, experiences.

The club membership has risen greatly since January, due to some concentrated advertising, and it is now limited only by the number of canoes and amount of equipment held in the club.

A new venture was entertained this summer, in which Canoeing was introduced to the Junior Entries' Squadron Sports Programme. Sixteen of these Apprentices were given comprehensive canoe training, in the hope that they will supply the club with some fairly experienced canoeists, when they become eligible to join.

Finally, the club bids farewell to its members in the 99th entry. Their departure means a great loss of experienced members, especially P. Sharman, who has been Secretary for two years and has done sterling work in the club, but we wish them every success for the future, in the canoeing world.

Future prospects for the club seem extremely bright and, with the co-operation and efforts of all members, next year should bring some interesting and successful canoeing, especially in the field of racing.

Locking Fencing Club

Reflections

The warm Whitsun sunshine signals the fencer temporarily to lay down his arms, to ponder upon recent battles fought, and to prepare for the renewal of old rivalries in September.

Looking back over the past season, one thinks with gratitude of Sgt. Macfarlane; of how he maintained our finances in good order, fought well and led well. Again, one thinks back to the tireless efforts of Sgt. Larvan; to his active participation and the way he shaped a band of beginners into a formidable youth schools' team. Both have now left the station, and we wish them every success. This gap in our ranks, however, has been quickly filled by the advent of Flt.-Lt. Warren and Fg./Off. Hutton, two experienced fencers, who will doubtless help the club to many future successes.

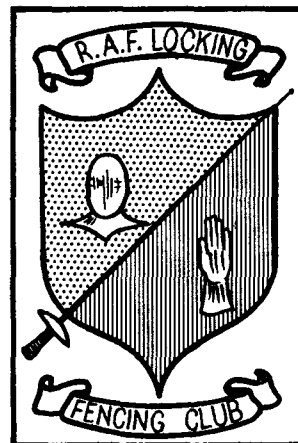

Elections

At a recent meeting, Flt.-Lt. Warren was elected "Captain of fencing" and Mr. D. Parker to the post of Treasurer. Both these posts fell vacant when Sgt. Macfarlane was posted. The election of a club coach was held over for further action by the committee. In the meantime, Mr. J. McKenzie and Flt.-Lt. Warren will maintain a beginners' class (men and women) on Thursdays at 1900 hours.

Competitions

Novice Plaque. A very lively competition as usual, and this year our lady foilist also competed. The experience gained proved invaluable to our youth schools' team.

The eventual winner was Mr. D. Parker.

Locking Master at Arms

Most club members entered for this competition and it provided some much needed competitive practice over several weeks. Flt.-Lt. Warren is to be congratulated on winning each individual weapon. The first four in the final placings were: Master at Arms 1963-64, Flt.-Lt. D. Warren; 2nd, Sgt. Larvan; 3rd, Sgt. Macfarlane; 4th, Mr. J. W. McKenzie.

Youth schools

In this event, held at R.A.F. Halton, both our Senior and Junior teams were runners-up to Halton by very narrow margins. Congratulations to all team members on a sterling performance. It was Locking's misfortune that this year Halton should have such a team of exceptional fencers.

Individual Honours—Foil: winner A.A. McCarthy (Locking); *Épée*—runner-up A.A. Leadbetter (Locking).

Royal Tournament

Phase I was run in conjunction with the Master-at-Arms competition. In Phase II, at R.A.F. St. Athan, our strength was sadly depleted by the enforced withdrawal from the team of Flt.-Lt. Warren and Sgts. Larvan and Macfarlane. In the individual section of Phase II, A.A.s Hill, Leadbetter and McCarthy did well, but not quite well enough to qualify for Phase III (R.A.F. Championships).

105th and 106th Entries

Our perennial problem, of course, is the selection and preparation of a youth schools' team for the coming season. We particularly appeal to members of the 105th and 106th entries to come forward as soon as possible if they feel they would like to take up a healthy and rewarding sport. Have a word with any fencer you know, or see Mr. J. McKenzie in No. 3 (T) Block or at the fencing salle on Thursday evenings at 7.30 p.m.

Congratulations

In conclusion we heartily congratulate J/T Lodge (ex 97th) on his selection to represent the R.A.F. versus Northern and Southern Ireland, and also on his fine performance in the Birch Shield. In the latter competition, he was placed 1st in both épée and sabre events, and tied equal first in the overall placings.

General Secretary.

Gliding

MENDIPS (R.A.F. LOCKING) GLIDING CLUB

The Club was formed in July 1963 and commenced flying operations in October of the same year. The aircraft at present in use are a T.21 Sedbergh Trainer and T.31 Tutor Trainer, although the Club does own two single seaters which are at present undergoing modification and repair.

Despite teething troubles, unserviceable winches, shortage of personnel and the added difficulties of bad weather which has prevented flying on numerous occasions, the Club has a very creditable record to date of over six hundred launches and forty hours' flying time. Six members have "gone solo" at Weston during this time and two others at the R.A.F. Gliding and Soaring Association Centre, Bicester.

Plans for the future include the provision of two more winches (a new diesel engine has already been purchased for one winch) and a ridge soaring programme is being worked out so that members may gain further experience in the art of soaring. This will be carried out at Halesland and should provide good sport for all. Plenty of work is available for those interested in mechanics (the installation of one diesel engine springs to mind!) and classes in airmanship and ground handling are to be included in the training programme.

The membership, although healthy, could certainly be improved and is open to all serving members of the Royal Air Force, their wives, and children over the age of fifteen years. The cost? Membership fees are 5s. per month or £3 per year, plus a fee of 2s. 6d. per winch launch and a small soaring charge for every period of ten minutes in excess of the first fifteen minutes. Should you like to "try before you buy" then by all means come down to Weston Airport any Tuesday, Wednesday or Saturday afternoon or all day Sunday for a trial flight before making up your mind. Further information can be obtained at the Club premises, which are located in the annexe of the R.S.T.F. hanger at Weston Airport.

LET THE EXPERT STAFF
of
COOKSLEY & SON

REMOVE YOUR FURNITURE

WITH CARE

10 WATERLOO STREET

and

21 WATERLOO STREET

WESTON-SUPER-MARE

Estab. 1887

Tel. 6666

HOUSE FURNISHERS
NOTED THROUGHOUT SOMERSET FOR QUALITY

Pasteurised Channel Island and T.T. Milk
Processing and Hygienic Dairy
Deliveries Everywhere

Suppliers to : R.A.F. Station Locking
Hospitals
Hotels
Schools

WESTON FARMERS

(D. R. Thomas Dairies Ltd.)

Severn House, 391 Locking Road East
WESTON - SUPER - MARE

Telephone : Weston-super-Mare 3520

WHY

LOOK FURTHER ?

||
THE

IMPERIAL
LAUNDRY

CAN MEET YOUR NEEDS FOR

Laundry, Dyeing and Dry Cleaning

LAUNDERERS TO R.A.F. OFFICERS'
MESS, LOCKING.

Works :
HIGH STREET
WORLE

Town
Depot :
53 ORCHARD ST.
Phone 3505

The Aircraft Recognition Club

Aircraft Recognition played an important role in the Second World War and almost the whole population of this country became amateur observers. In this present day and age the ability to rapidly identify an aircraft in flight is no less vital to our security. At Locking, the Aircraft Recognition Club is extremely active and works hard to maintain a high standard. During the last four months, the club has competed twice against the Royal Observer Corps, and has been victorious on both occasions.

It does not, however, restrict itself to indoor work, and, now that summer is here, members are looking forward to a series of visits to all the great air displays. The season has already opened in fact, with a visit to the International Air Fair at Biggin Hill.

New members are always welcome at club meetings, which take place every Wednesday evening, at 1830 hours.

Golf

R.A.F. LOCKING GOLF SOCIETY

Golf, at 6 shillings per month (Officers), or 2 shillings per month for other ranks! What more could all you would-be golfers ask? This ridiculously low premium affords an opportunity for even the lowest paid individual to participate in what is becoming an ever-increasing popular sport. Excellent facilities are provided at both Worlebury Golf Club and Weston-super-Mare G.C. for Officers, and at Worlebury G.C. only, for other ranks. Station and Inter-Station fixtures have provided some "stimulating" competitive sport in the past few weeks. The station was recently represented by Sqn-Ldr. C. Henderson, Flt-Lt. W. Eadon, Sgt. Paull and Sgt. Porter at a R.A.F. West of England Inter-Station championships played at Sham Castle G.C. Bath. Although the weather conditions were atrocious, with high winds and heavy rain, a good day's golf was had by all. The Station should be congratulated in gaining a 7th position out of 15, and in particular, Sgt. Porter in winning the second division Stableford competition, with 30 points. His handicap has since been reduced to 9. Sgt. Paull (Handicap 1) has been selected to represent Technical Training Command at the R.A.F. championships, to be held at Burnham and Berrow G.C. during the week 25th-29th May 1964. Future fixtures include interstation competitions at the 24 Group championships and an invitation to compete in a new "Queen's Birthday competition" at Sleaford G.C. on the 3rd June, 1964. The annual outing of the society is to be held at Weston-super-Mare G.C. on Wednesday, 8th July, 1964, and will consist of a morning Medal round and afternoon Bogey competition. This is your opportunity to have a good day's golf and, maybe, walk away with one of the prizes.

**THE SIGN OF GOOD CLOTHES
REASONABLY PRICED !
MEN'S, LADIES' Tailors and Outfitters**

**BIG
AND
SMALL**



**WE
"SUIT"
THEM
ALL**

**Boys' and Girls School Wear Specialists
Out of School Wear and Teen Fashions**

COUCH & SONS
ESTABLISHED OVER 85 YEARS

**A Shop for every member of the Family
21, 25 27 ST. JAMES STREET
WESTON-SUPER-MARE
Tel. 1374-5**

Telephone : Banwell 52

**CHOICE FLOWERS : POT PLANTS
WREATHS : WEDDING BOUQUETS**

Leonard Jones

F.R.H.S.

Member of Interflora (We Telegraph Flowers)

**GLADIOLI : DAHLIAS
CHRYSANTHEMUMS
a Speciality**

**SPRINGFIELD NURSERIES
KNIGHTCOTT : BANWELL
SOMERSET**

For all Sports Goods

come to a Sportsman

BILL ANDREWS

(Official Supplier to Bristol Rovers and
Bristol City Football Clubs)

UPHILL SPORTS STORE

Telephone Weston 5477

SERVICE AND SATISFACTION

Table Tennis Club

The Club's "A" and "B" teams had a successful season in the North Mendip League and were placed 3rd and 4th respectively. In the Royal Air Force Cup the station team, comprising A.A.s Randel, Heslop and Chan, reached the semi-final of the Western Area and were then narrowly defeated by St. Mawgan.

Locking Saddle Club

Locking does not have a Riding Stable of its own, but it does have a flourishing Saddle Club with good facilities catering for beginners and experienced horsemen (women). Horses are made available by Mr. J. Vowles, of Weston-super-Mare. On sports afternoons and at weekends it is normal to see members of the Locking Saddle Club cantering on the Sands or wending their way through the woods at Weston. The Saddle Club was represented at R.A.F. Equitation Championships held at Cranwell, on 30th May this year.

Ex-Apprentice Corner

A PLEA

Owing to rising printing costs and the smaller number of apprentices now serving at No. 1 Radio School, the *Locking Review* is in danger of going out of publication. The only way it can be saved is by increasing sales to ex-apprentices.

Now it must be admitted that at present there is little in the *Review* of any interest to those who have passed-out some time ago. This situation is one the editorial staff would like to change. To do so, however, we must have the views of our prospective readers.

Two ideas so far suggested are: More articles of an up-to-date technical nature, making the *Review* something on the lines of the *Radio cum Electronics Journal* of the Royal Air Force, or, more personal details of those who have left, making the journal the organ of an "Old Boys" Association.

Well, there it is. What are your views? If you have any suggestions please write either to the Editor or the Business Manager at Locking.

K. G. EVANS,
Business Manager.

EX-APPRENTICE NEWS

Congratulations to Ex-Corporal HOM (ex-89th) on being commissioned last January.

Congratulations also to the following on their promotion to Corporal:

BARRY (90th)
SIMMS (91st)
BACON (93rd)
STRUTT (94th).

We hear that J/T HARVEY (98th) is now engaged to be married. We would like to offer our best wishes to him and his fiancée.

ROYAL AIR FORCE LOCKING

Art, Photography and Handicraft EXHIBITION

ENTRIES will be JUDGED on 18th SEPTEMBER, 1964

EXHIBITION OPEN FOR VIEWING on 21st-23rd SEPTEMBER

in the

STATION EDUCATION CENTRE

