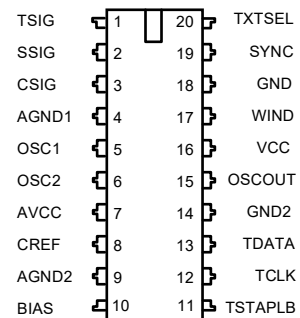

**UNIVERSAL TELETEX SYSTEMS
Teletext DATA SLICER
CF72416**

Draft 3

CONTENTS

DESCRIPTION.....	3
INTERNAL BLOCK DIAGRAM OF CF72416	4
PIN DESCRIPTION	5
COMPOSITE VIDEO INPUT DESCRIPTION	6
VIDEO INPUT SPECIFICATION	9
ABSOLUTE MAXIMUM RATINGS	10
RECOMMENDED OPERATING CONDITIONS	10
PACKAGE DIMENSIONS	11
APPLICATIONS CIRCUIT (WITH CF72407).....	12
APPLICATIONS CIRCUIT (WITH CF70200).....	14
APPLICATIONS CIRCUIT (WITH CF70095 OR CF70195)	15
SUPPLEMENTARY APPLICATIONS INFORMATION	16

- Extracts both Teletext and VPS data
- Forms a custom 2-chip solution when used with an ASICTEXT decoder
- Low power 1 μ CMOS (<100mW)
- Standard 20 pin/300mil package
- Tolerates a range of video distortions
- Operates with 13.875 MHz fundamental mode crystal



CF72416

20-pin/300 mil N Plastic

DESCRIPTION

The CF72416 is a new device comparable with the currently available CF72306 but having the added capability of extracting 'Video Programming System' (VPS) data. The CF72416 forms the Analogue component of the Texas Instruments (TI) teletext system.

The device extracts from the incoming video signal both composite sync and Teletext/VPS data. From the Teletext/VPS data it also regenerates the appropriate frequency clock signal. It passes the clock, data and composite sync to the digital decoder chip. Both Teletext and VPS use the same data and clock pins, the different signals being identified by the appropriate decoder.

The CF72416 device has the following features and enhancements over the CF72306:-

1. VPS data decoding.
2. Improved adaptive slicing level for the Sync separator and sync noise information added to composite sync which when used with Texas Instruments' Multipage and Eurotext decoders gives improved locking performance.
3. Minor board changes are required to upgrade to the CF72416 from the CF72306.

The crystal oscillator is the same as used with the CF72306. The crystal specification is given below:-

13.875MHZ Crystal Specification

- Oscillation Mode.....Fundamental Parallel
- Frequency.....13.8750MHz
- Crystal Frequency Stability..... ± 150 ppm *
- Maximum Crystal ESR (steady-state).....60 Ohms
- Maximum Crystal ESR (start-up).....120 Ohms
- Maximum Shunt Capacitance.....7 pF
- Maximum Motional Capacitance.....30 fF
- Crystal Load Capacitance.....18 pF
- Free Air Operating Temperature Range.....0 to 70 °C
- Drive Level.....1mW max.
- Ageing..... ± 5 ppm max. for first year

* includes temperature stability and manufacturing tolerance.

Internal Block Diagram of CF72416

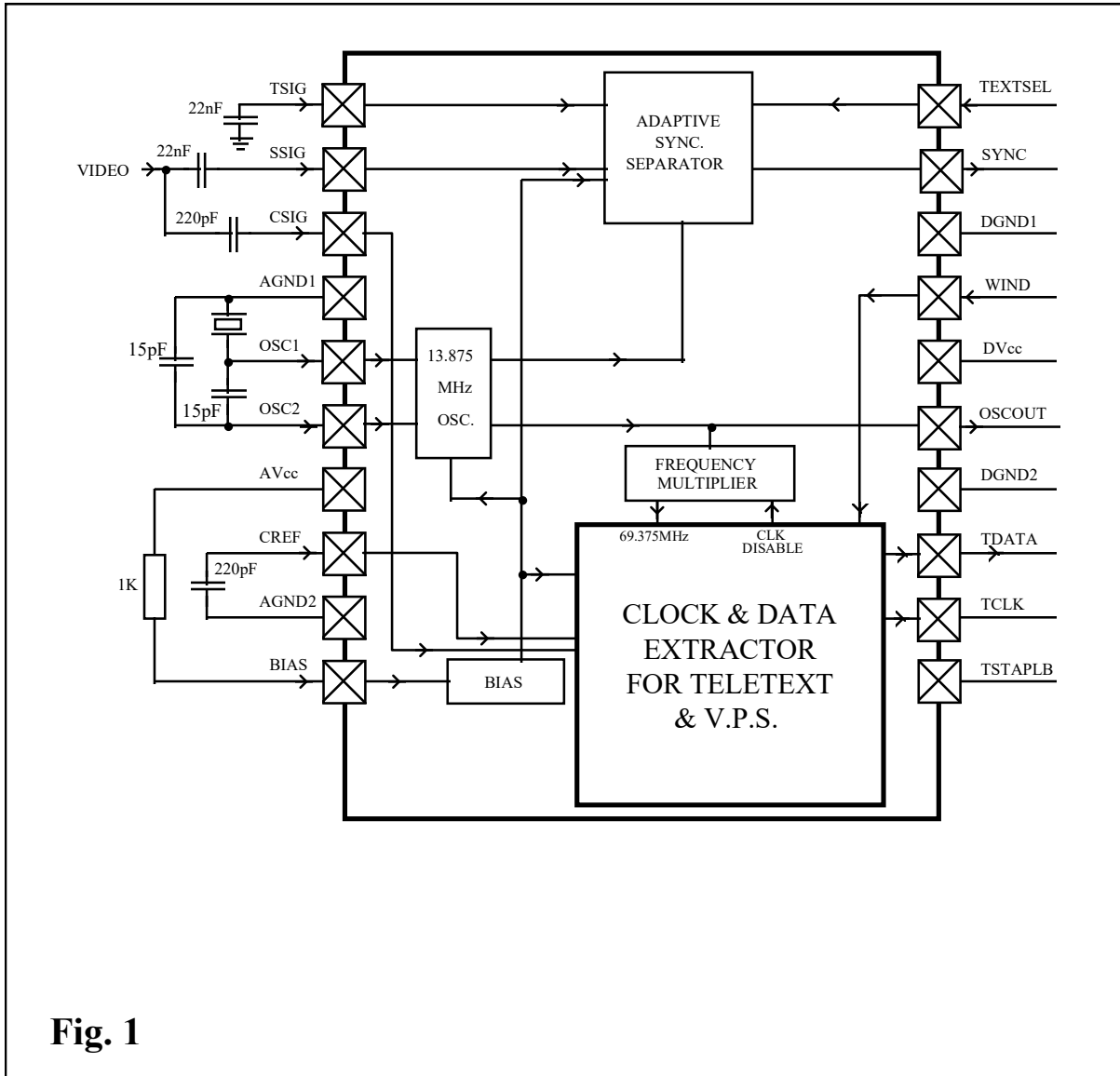

Fig. 1

Pin description

PIN	SIGNAL	DESCRIPTION	I/O	TYPE
1	TSIG	Video Sync Reference	I	Analogue
2	SSIG	Video Sync Input	I	Analogue
3	CSIG	Video Data Input	I	Analogue
4	AGND1	Analogue Ground		Power
5	OSC1	13.875 MHz Oscillator	I	Analogue
6	OSC2	13.875 MHz Oscillator	I	Analogue
7	AVCC	Analogue Vcc		Power
8	CREF	Video Data Reference Input	I	Analogue
9	AGND2	Analogue Ground		Power
10	BIAS	Internal Reference	I	Analogue
11	TSTAPLB	Test/Application	I	Digital
12	TCLK	Teletext Clock	O	Digital
13	TDATA	Teletext Data	O	Digital
14	DGND2	Digital Ground		Power
15	OSCOUT	Oscillator Output	O	Digital
16	DVCC	Digital Vcc		Power
17	WIND	Timing Signal	I	Digital
18	DGND1	Digital Ground		Power
19	SYNC	Separated Sync Output	O	Digital
20	TEXTSEL	Sync Noise Select Note 1	I	Digital

Signal pins = 14

Power pins = 6

Note 1: This pin should be left open (N.C.) when used with the Unitext or Eurotext Decoder and connected to ground when used with Multipage decoders.

Composite video input description

(Please note that the following diagrams relate to the teletext data line. However, VPS data will exhibit similar degradation.)

The composite video input to the CF72416 has the following form in the nominal case.

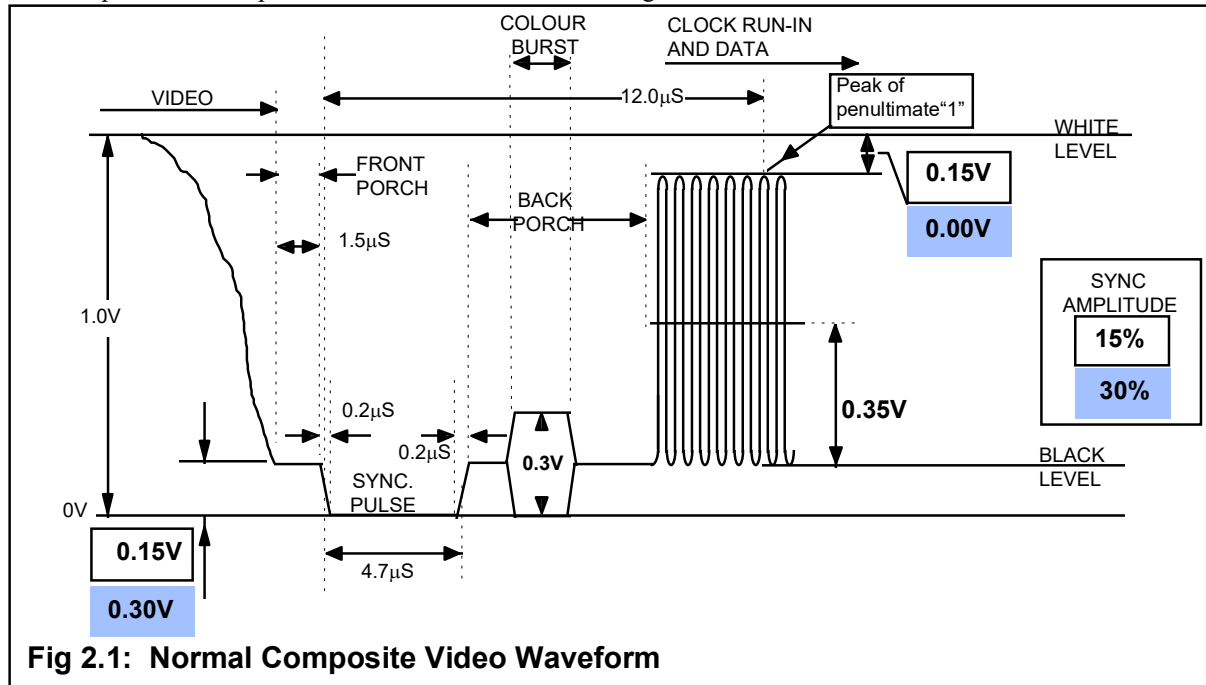

Fig 2.1: Normal Composite Video Waveform

The composite video input to the CF72416, when subject to the worst case amplitude tolerances resulting from both low and high frequency distortions, has the forms shown in the following four diagrams. Parameter values are shown in Table 2.2.

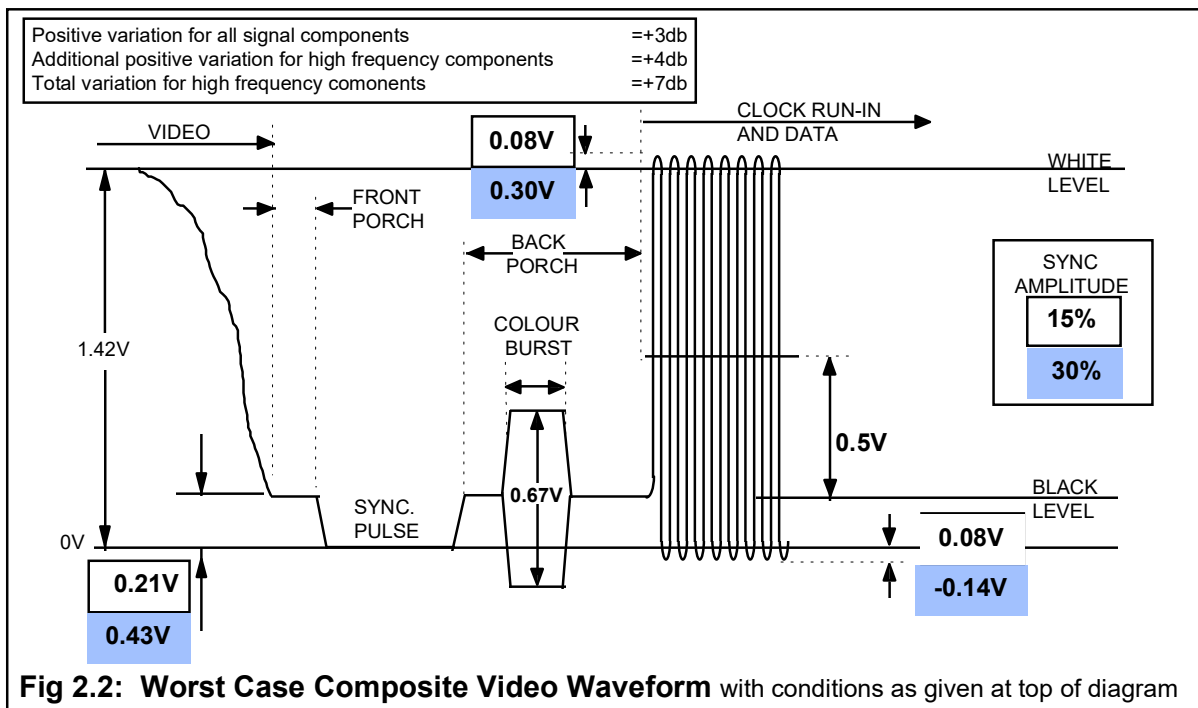
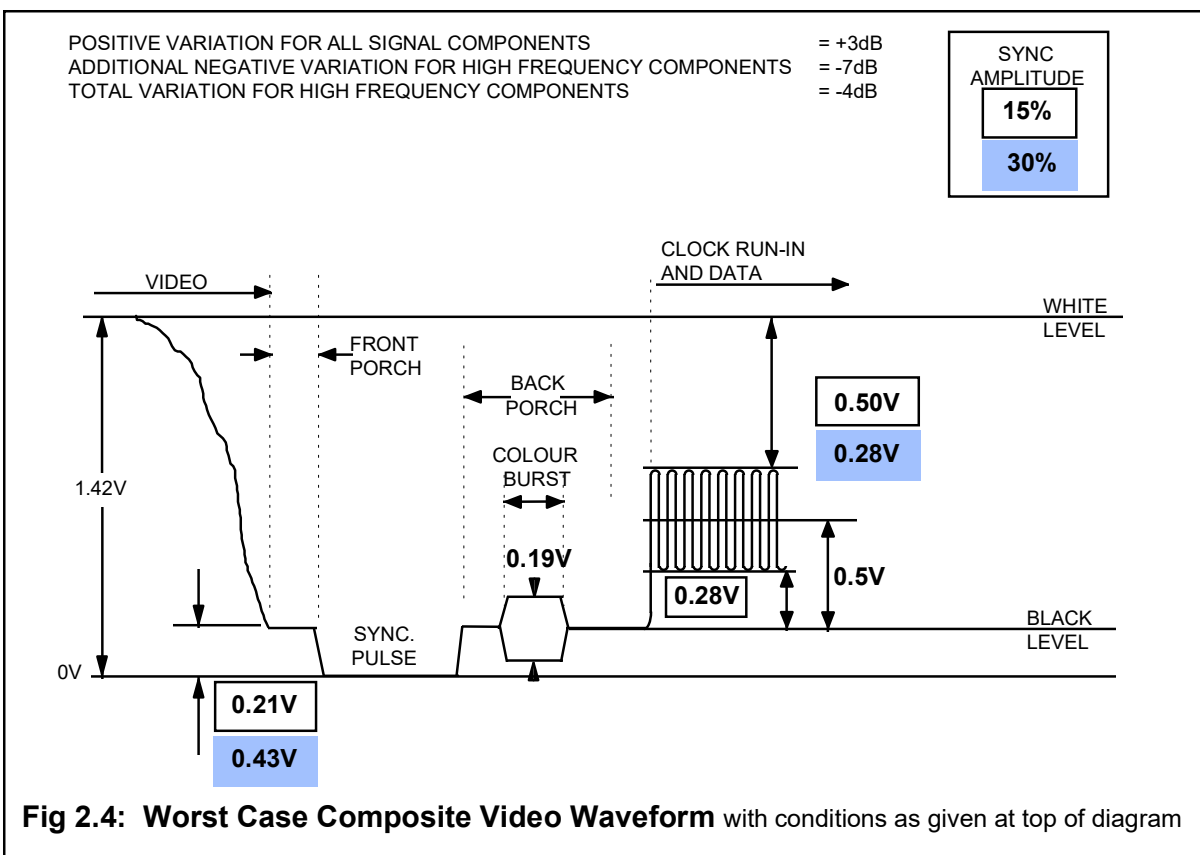
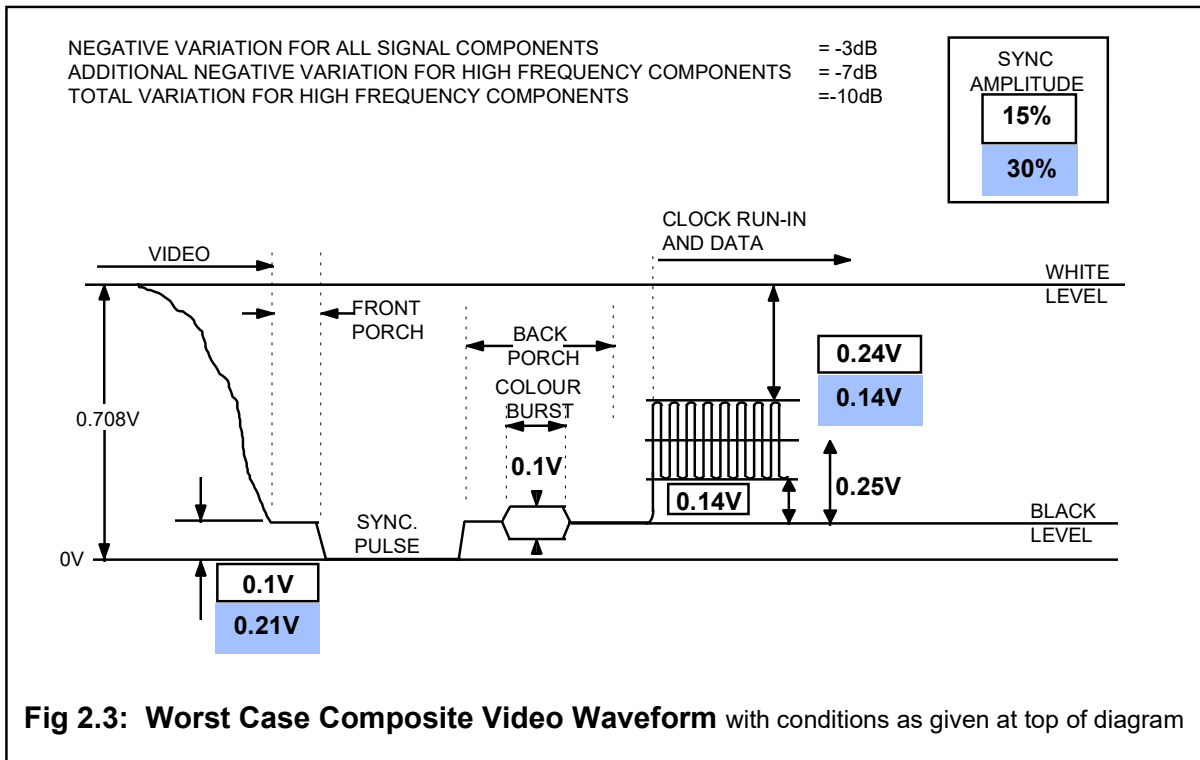
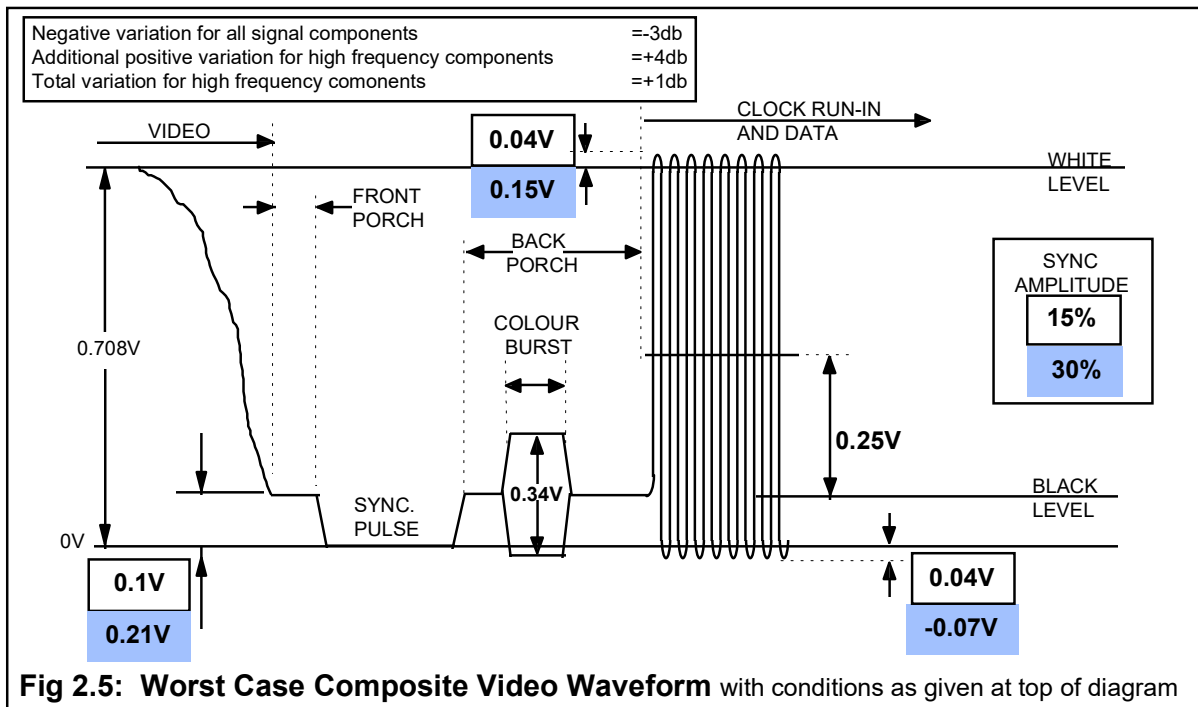

Fig 2.2: Worst Case Composite Video Waveform with conditions as given at top of diagram

Composite Video input description - continued.



Composite video input description - continued



The composite video input to the CF72416 has the following timing specification. All amplitudes in this figure have nominal reference values as shown in Figure 2.1.

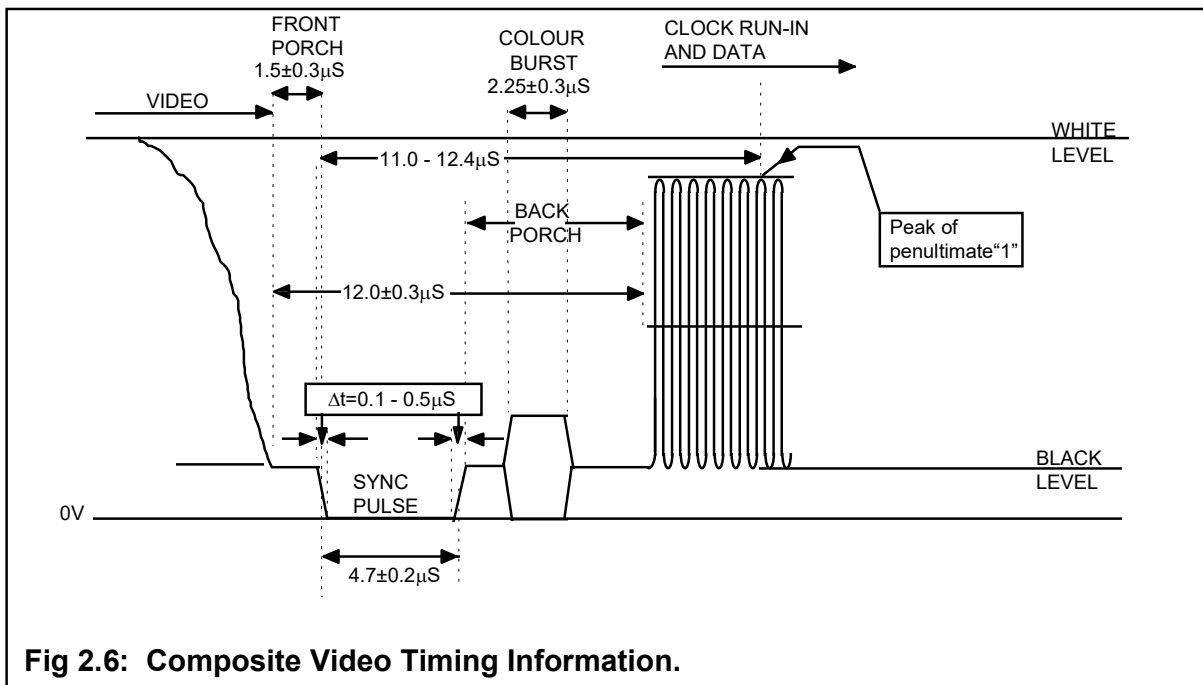

VIDEO INPUT SPECIFICATION

PARAMETER	MINIMUM	NOMINAL	MAXIMUM	UNIT	Notes
Composite Video Amplitude(peak-to-peak)	0.708	1.0	1.42	V	
Source Impedance	-	-	350	Ω	
Sync Amplitude	10	-	43	% Nominal Video	1
Sync Duration	4.5	4.7	4.9	μ s	2
Sync Transition Times	0.1	0.2	0.5	μ s	3
Front Porch	1.2	1.5	1.8	μ s	
Under/Overshoots	-	-	20	% Nominal Video	4
Time between -ve sync & penultimate '1' of Clock Run-in	11	12	12.4	μ s	5
Line Blanking	11.7	12.0	12.3	μ s	6
Colour Burst Amplitude (peak-to-peak)	9	30	67	% Nominal Video	
Colour Burst Frequency	-	4.43	-	MHz	
Colour Burst Duration	1.95	2.25	2.55	μ s	
Clock Run-in Amplitude	22	70	157	% Nominal Video	7
Number of Complete & Consecutive Clock Run-in cycles	4	-	8		8
Bit rate - VPS	2.4997	2.5000	2.5003	Mbps	
Bit rate - Teletext	6.9373	6.9375	6.9377	Mbps	
Data "one" level	19	66	161	% Nominal Video	
Data "zero" level	-6	0	6	% Nominal Video	9

Note 1: Minimum value is: low frequency -3db and 15% sync.

Maximum value is: low frequency +3db and 30% sync

Note 2: As measured at 50% of the total sync. amplitude.

Note 3: As measured at 10% and 90% of the total sync. amplitude.

Note 4: Under/Overshoots are of order of 100nS duration.

Note 5: As measured at 50% of the negative sync transition and the peak of the penultimate "1"

Note 6: As measured at 50% of the negative and positive edges of adjacent peak white components which are respectively before and after a sync pulse.

Note 7: Clock Run-in envelope - Raised cosine filter with centre frequency at 3.46875 for teletext or 2.5000MHz for VPS.

Skew symmetrical about 0.5 x bit rate and substantially reduced at 5MHz.

Note 8: A clock run-in cycle is complete if its amplitude equals or exceeds 22% of composite video.

Note 9: With the black level as a zero reference.

Absolute Maximum Ratings

Supply Voltage, V _{cc}	6.5V
Input Voltage.....	V _{cc} + 0.5V
Current Any signal pin	±20mA
Current V _{cc} or GND	±50mA
Operating free air temperature range	0°C to 70°C
Storage Temperature range.....	-65°C to 70°C
Thermal Resistance θ _{ja}	150°C/W

Recommended Operating Conditions

Symbol	Parameter	Test Conditions	min.	nom	max.	unit
F _o	Operating Freq.			13.875(*)		MHz
Supplies						
V _{cc}	Supply Voltage	V _{ih} = min V _{il} = min	4.5	5.0	5.5	V
Inputs - Digital:- WIND, TSTAPLB (CMOS inputs)						
V _{ih}	High Level input Voltage		0.7V _{cc}			V
V _{il}	Low Level input Voltage				0.2V _{cc}	V
I _{ih}	Input Current High	V _{cc} = max.	-1		+1	μA
I _{il}	Input Current Low	V _{cc} = max.	-1		+1	μA
TEXTSEL (CMOS input with pull up.)						
V _{ih}	High Level input Voltage		0.7V _{cc}			V
V _{il}	Low Level input Voltage				0.2V _{cc}	V
I _{ih}	Input Current High	V _{cc} = max. V _{ih} = V _{cc}	-1		+1	μA
I _{il}	Input Current Low	V _{cc} = max. V _{ih} = V _{cc}			380	μA
Outputs - Digital TCLK, TDATA, SYNC, OSCOUT						
V _{oh}	Output Voltage High	V _{cc} =min I _{oh} =30μA =300μA =3mA		V _{cc} -100mV V _{cc} -200mV 3.76		V
V _{ol}	Output Voltage Low	V _{cc} =min I _{ol} =30μA =3mA			100 500	mV mV

(*) 2 X (Teletext data rate - 6.9375MHz)

Note 1: It is recommended that PCB track capacitance on OSCOUT should not exceed 22pF.

Note 2: It is recommended that PCB track capacitance on TCLK and TDATA should not exceed 33pF

Package Dimensions

20-Pin Plastic Dual-in-line Package
(20-Pin N Plastic)
Dimensions in millimetres (inches)

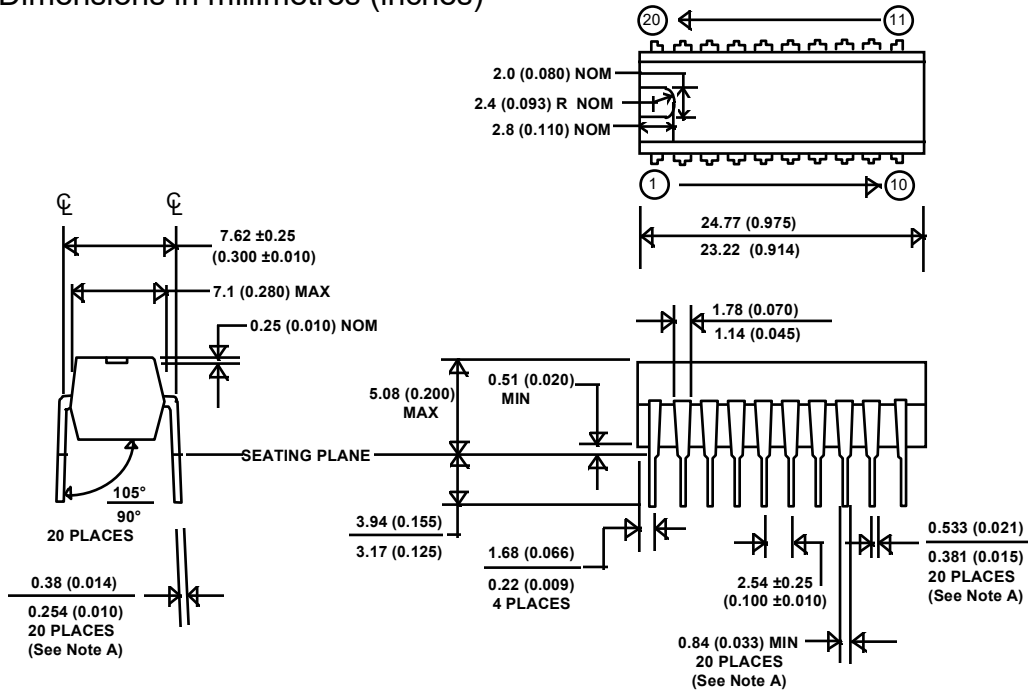

Note : A. This dimension does not apply for solder dipped leads.

Fig 3.

20 pin Small Outline Package. Pin-out is the same as DIL package.

DWT (R-PDSO-G20)

PLASTIC SMALL-OUTLINE PACKAGE

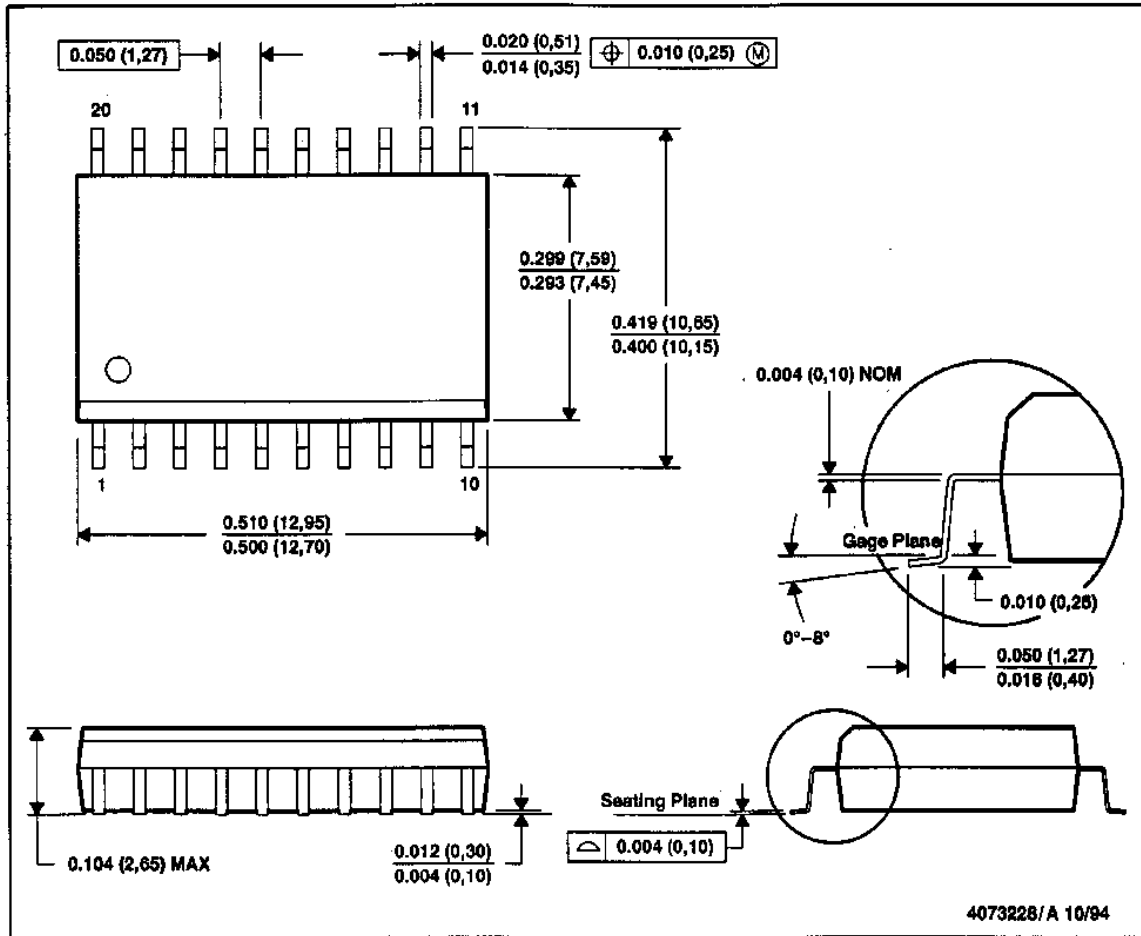

- NOTES:
- All linear dimensions are in inches (millimeters).
 - This drawing is subject to change without notice.
 - Thermally enhanced molded plastic package with four center leads connected to die pad
 - Falls within JEDEC MS-013

Applications Circuit (with CF72407)

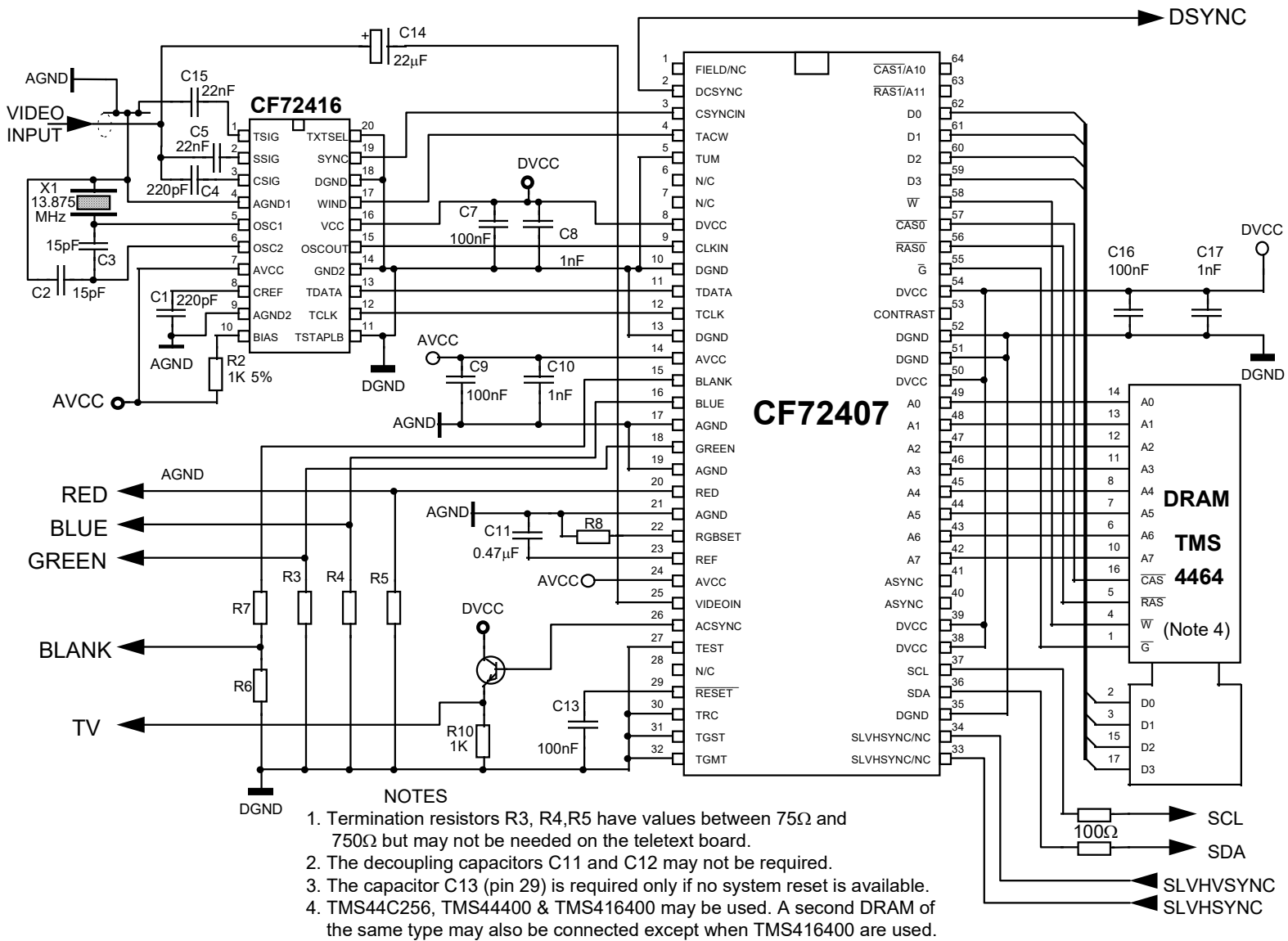

Applications Circuit (with CF70200)

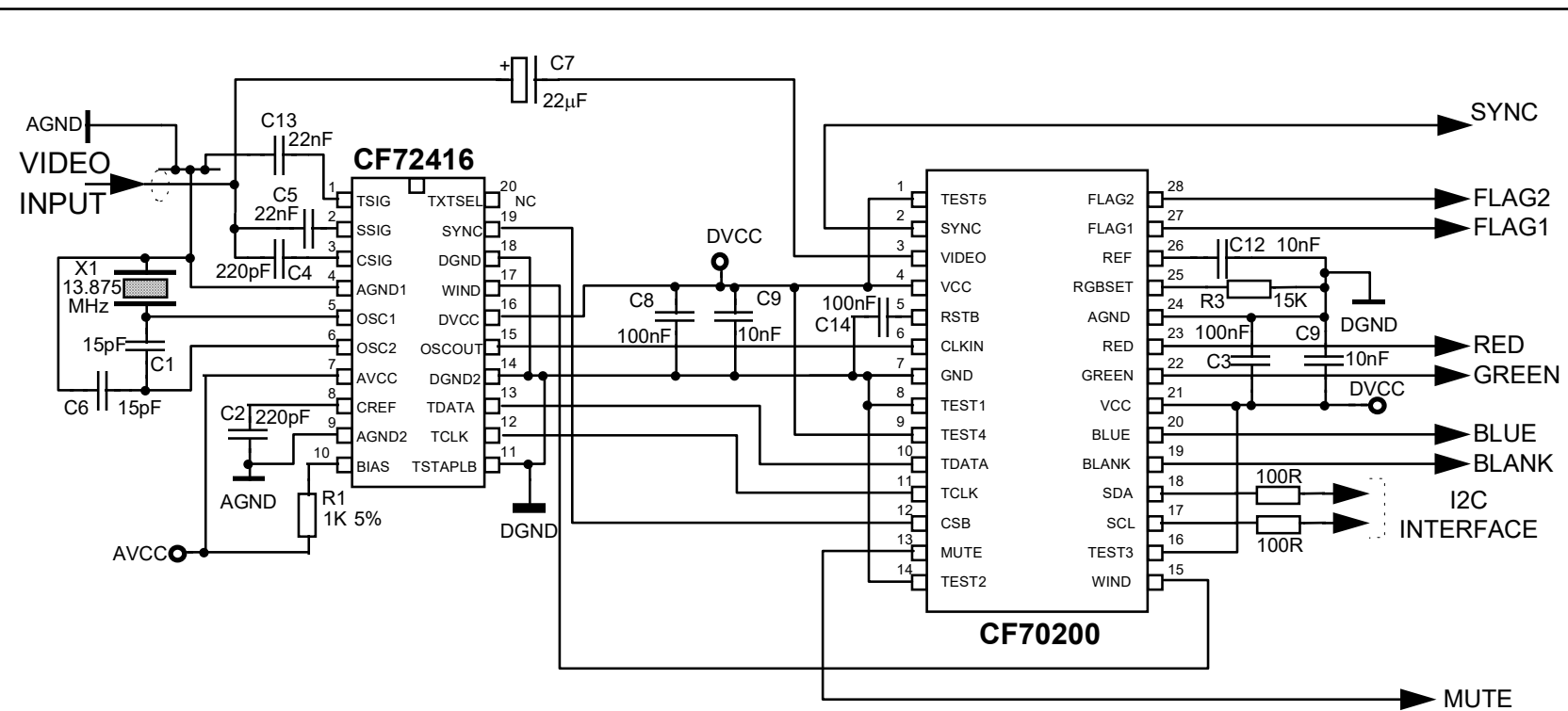

NOTE: For best operation, AGND2 and C2 ground should be directly connected to the Ground at the Video input source.

Applications Circuit - Data Slicer CF72416 and Eurotext Decoder CF70200

Applications Circuit (with CF70095 or CF70195)

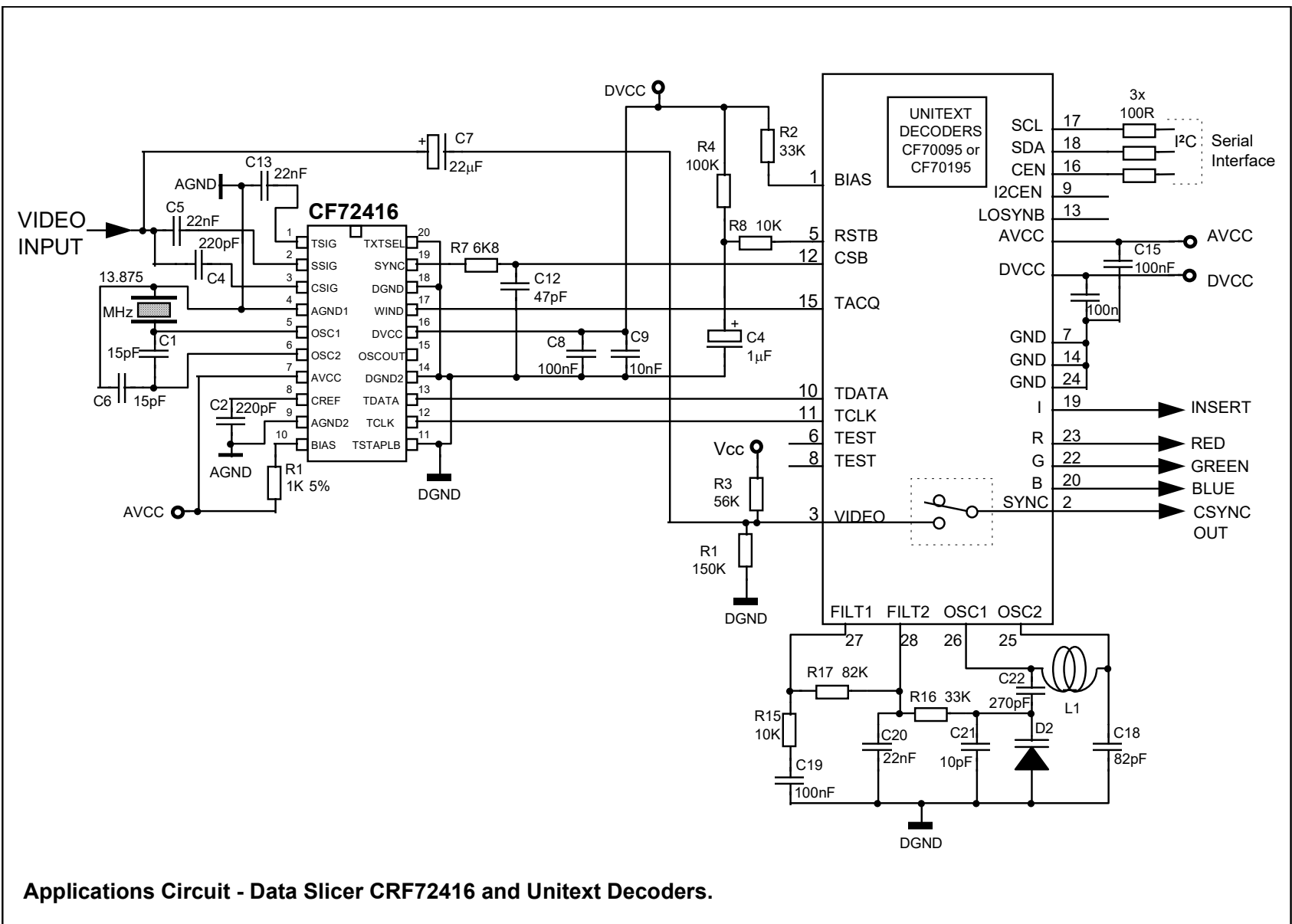

Applications Circuit - Data Slicer CRF72416 and Unitext Decoders.

Supplementary Applications Information

(required for stand-alone applications)

The following information will be required when the Data Slicer is not used in conjunction with a Texas Instruments single or multi-page teletext decoder:-

1. TDATA and TCLK outputs are static low when WIND input is static low or when the VIDEO input contains invalid teletext or VPS clock run-in data.
2. Phase Relationship between TDATA and TCLK signals:

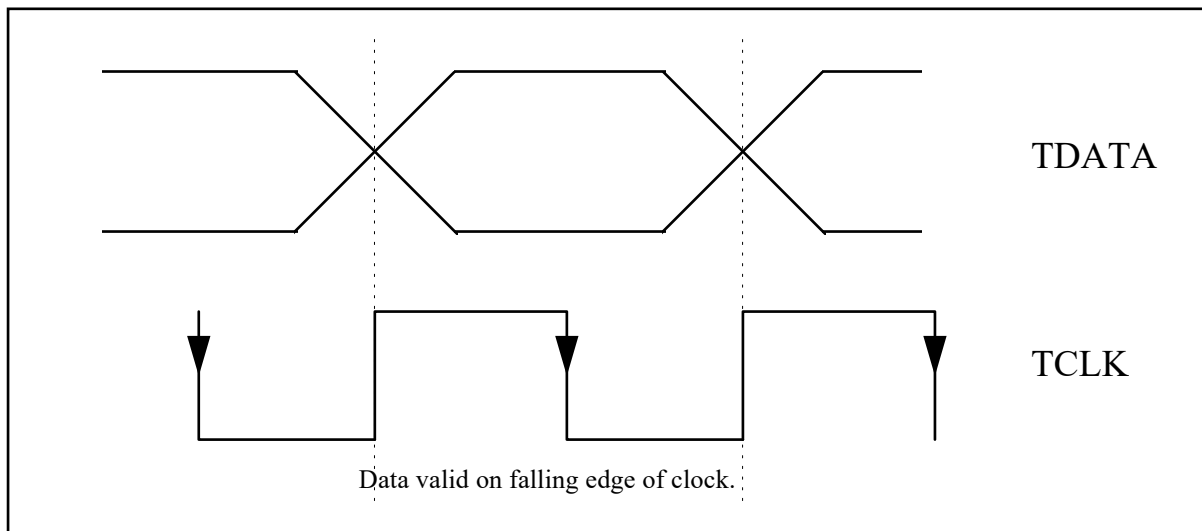

Fig. 7: TDATA and TCLOCK Timing

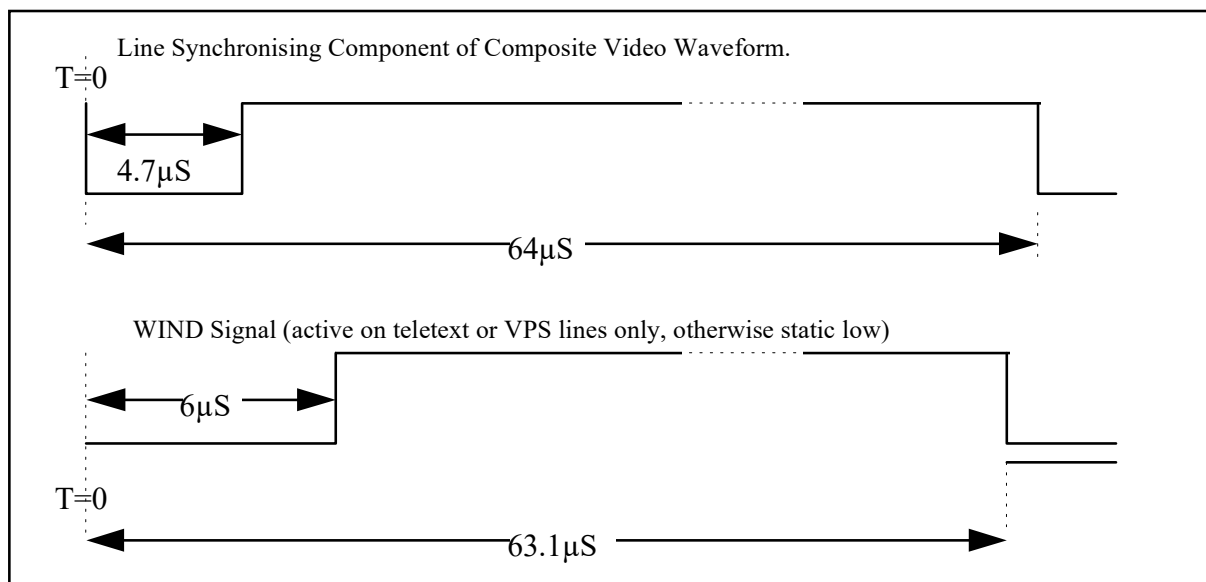

Fig. 8: Window Signal Timing

Notes:

1. T=0, above, can be coincident with, or up to 1.5µS later than, negative video line SYNC edge
2. All timings may sustain a tolerance of ±5%.

IMPORTANT NOTICE

Texas Instruments (TI) reserves the right to make changes to or to discontinue any semiconductor product or service identified in this publication without notice. TI advises its customer to obtain the latest version of the relevant information to verify, before placing orders, that the information being relied on is current.

TI warrants performance of its semiconductor products to current specifications in accordance with TI's standard warranty. Testing and other quality control techniques are utilised to the extent TI deems necessary to support this warranty. Unless mandated by government requirements, specific testing of all parameters of each device is not necessarily performed.

TI assumes no liability for TI applications assistance, customer product design, software performance, or infringement of patent: or services described herein. Nor does TI warrant or represent that any licence, express or implied, is granted under any patent right, copyright, mask work right, or any other intellectual property right of TI covering or relating to any combination, machine, or process in which such semiconductor products or services might be used.

Copyright © 1995, Texas Instruments Ltd